



OMNI-Test Laboratories, Inc.

EPA Standard of Performance for New Residential Wood Heaters

Certification Test Report

Non-Confidential Business Information (Non-CBI)

Manufacturer: Hearth & Home Technologies, Inc.
Heater Type: Pellet-Fired, Insert
Model: Classic Bay 1200I-C

Prepared for: Hearth & Home Technologies, LLC
352 Mountain House Rd.
Halifax, PA 17032
USA

Prepared by: OMNI-Test Laboratories, Inc.
13327 NE Airport Way
Portland, OR 97230
(503) 643-3788

Test Period: December 18, 2018

Report Date: February 1, 2019
Report Revision Date: February 19, 2024

Report Number: 0061PN013E

All data and information contained in this report are confidential and proprietary to Hearth & Home Technologies. Its significance is subject to the adequacy and representative character of the samples and to the comprehensiveness of the tests, examinations, or surveys made. The contents of this report cannot be copied or quoted, except in full, without specific, written authorization from Hearth & Home Technologies and OMNI-Test Laboratories, Inc. No use of the OMNI-Test Laboratories, Inc. name, logo, or registered mark (O-TL) is permitted, except as expressly authorized by OMNI-Test Laboratories, Inc. in writing.

Hearth & Home Technologies, LLC
Model: Classic Bay 1200L-C
Project: 0061PN013E

AUTHORIZED SIGNATORIES

This report has been reviewed and approved by the following authorized signatories:

Evaluator:

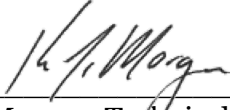

Ken Morgan, Technical Services Director
OMNI-Test Laboratories, Inc.

TABLE OF CONTENTS

PREFACE.....	(3 pages)
Section 1 –Appliance, Testing, & Results	4
1.1 Summary Tables	5
Table 1 – Particulate Emissions	5
Table 2 – Efficiency and CO	5
Table 3 – Test Facility Conditions	6
Table 4 – Heater Configuration	6
Table 5 – Train Precision	6
1.2 Procedures & Results Summary	7
1.3 Appliance Description	8
Section 2 – Test Data	11
2.1 Test Data by Run.....	12
2.2 Sample Analysis & Tares	32
Section 3 –Laboratory Quality Assurance	40
3.1 Quality Assurance/Quality Control.....	41
3.2 Calibration Data	42
3.3 Example Calculations.....	57
Appendix A – Labeling & Owner’s Manual	
Appendix B – Dilution Tunnel Used & Schematic	
Appendix C – Revision History	

Section 1

Appliance, Testing, & Results

- 1.1 - Summary Tables
- 1.2 - Procedures and Results Summary
- 1.3 - Appliance Description

1.1 - Summary Tables

Table 1 – Particulate Emissions

	One-Hour Filter	Integrated Total
¹ Corrected Emission Rate (g/hr)	0.987	0.782
Emission Factor (g/dry kg)	0.407	0.698
² Uncorrected Emission Rate (g/hr)	0.987	0.854

¹Corrected refers to gravimetric analysis that takes negative filter weights as a negative value in cases where filter residue was transferred to (stuck to) O-ring gaskets to account for the mass transfer.

²Uncorrected refers to gravimetric analysis where negative filter weights are taken as zero, thus reporting a higher value by overreporting of transferred filter material. The uncorrected values were added to this report in response to a request by the US EPA.

Table 2 – Efficiency and CO

	Burn Rate Segment			Integrated Total
	Maximum	Medium	Minimum	
Time (minutes)	60	120	180	360
Burn Rate (dry kg/hr)	2.424	0.872	0.851	1.12
Heat Input Rate (BTU/hr, HHV)	48,501	17,443	17,018	22,407
Heat Output Rate (BTU/hr, HHV)	33,925	10,421	10,182	14,239
Efficiency (% , HHV)	69.9%	59.7%	59.8%	63.6%
Efficiency (% , LHV)	74.5%	63.6%	63.7%	67.6%
CO Emission Rate (g/min)	0.06	0.10	0.20	0.14

1.1 - Summary Tables

Table 3 – Test Facility Conditions

	Initial	Middle	Final
Room Temperature (°F)	70	68	70
Barometric Pressure (in Hg)	30.01	30.02	30.02
Air Velocity (ft/min)	<50	<50	<50
Induced Draft (in H2O)	ϕ	ϕ	ϕ

Table 4 – Heater Configuration

	Pretest	Burn Rate Segment		
		Maximum	Medium	Minimum
Heat Output Setting	Heat setting on High, FRAP set to fully open, control board set to 2. (max), Fan is automatic	Heat setting on High, FRAP set to fully open, control board set to 2. (max). Fan is Automatic	Heat setting on low, FRAP set to fully closed, control board set to 2. (max) Fan is Automatic	Heat setting on low, FRAP set to fully closed, control board set to 1. (min) Fan is Automatic

Note: During preburn a clamp weighing 1.7 pounds was added to the stove to hold a fuse in place due to a broken fuse holder. This weight had no effect on BTU input during the actual test.

Table 5 – Train Precision

Percent	g/kg
1.28%	0.02

1.2 - Procedures and Results Summary

TESTING PROCEDURE

The Classic Bay 1200I-C was tested in accordance with the U.S. EPA 40 CFR Part 60, Subpart AAA – Standards of Performance for New Residential Wood Heaters using ASTM E2515 and ASTM E2779. The model was tested for thermal efficiency and carbon monoxide (CO) emissions in accordance with CSA B415.1-10. The fuel used for certification testing was Pres-to-Log brand soft wood pellet fuel; this fuel was graded as Premium by the Pellet Fuels Institute and was produced at registered mill # 03208. Particulate emissions were measured using dual sampling trains consisting of two sets of filters (front and back).

A single test run was performed. The unit was installed and adjusted in accordance with the manufacturer's instructions.

The appliance was operated in accordance with the manufacturer's instructions in the Owner's Manual. The manufacturer's instructions specified operating the preburn and high burn segments at maximum heat setting, the "FRAP" (feed rate adjustment plate) fully open, and the control board trim switch set to 2. The medium burn segment was operated at heat setting medium, FRAP set to fully closed, and the control board switch set to 2. The low burn segment at minimum heat setting, FRAP set to full closed, and the control board switch set to 1.

RESULTS SUMMARY

Proportionality results of the integrated test run, in addition to all other validity criteria, were within specified limits, and no sampling anomalies occurred. All burn rate categories were achieved. Therefore, this test run is considered valid and appropriate.

The Classic Bay 1200I-C results indicate an average particulate emission rate of 0.782 g/hr. The results are within the emission limit of 2.0 g/hr for affected appliances manufactured on or after May 15, 2020.

The heater demonstrated an average thermal efficiency of 63.6%. The calculated CO emission rate was 0.14 g/min.

Upon completion of emissions certification testing, the sample unit was sealed and will be stored by the manufacturer in accordance with the requirements of the CFR.

1.3 - Appliance Description

Appliance Manufacturer: Hearth & Home Technologies

Pellet Stove Model: Classic Bay 1200I-C

Type: Fireplace insert, air-circulating type, pellet-fired room heater.

The Classic Bay 1200I-C's principle elements include a fuel hopper, ductile Iron burn pot, and electrical fuel feed, combustion air, and convection air supply systems. The frame of the unit is constructed of mild steel, as is the outer fascia.

Combustion products are routed out of the firebox chamber via a baffle-type heat exchanger through a 3-inch diameter flue outlet located on the rear of the unit. A 3" to 6" vent pipe adaptor was used for testing; this adaptor is shown in the manual as an approved installation.

Fuel is supplied from the hopper to the burn pot via a screw-type auger, mounted diagonally. Fuel supply rate is varied by cycling the auger motor as needed.

Ashes fall through the burn pot into a removable ash drawer located at the bottom of the unit. The drawer is accessed through a mild steel door, distinct from the cast aluminum front firebox door, which also features a 13.9 x 11.0" glass panel.

The electrical systems are regulated by a single user-operated toggle switch that operates the three heat settings. An adjustable slide plate (FRAP) is in the hopper, this plate is used to restrict the number of pellets that can enter the auger from the hopper. An additional trim setting is located on the control board, this control is only intended to be manipulated by a dealer representative at the time of initial installation. It was used during testing to obtain data at maximum and minimum settings.

More detailed information is shown in the manufacturer's design drawings, Appendix C of this report. This information is considered confidential business information (CBI) by the manufacturer and is not included in the non-CBI version of this report.

Hearth & Home Technologies, Inc.
Model: Classic Bay 1200I-C
Project: 0061PN013E



Appliance Photographs
Classic Bay 1200I-C
Test Date: 12/18/2018



Classic Bay 1200I-C Front



Classic Bay 1200I-C Back



Classic Bay 1200I-C Left



Classic Bay 1200I-C Control

Section 2

Test Data

2.1 Test Data by Run

2.2 Sample Analysis & Tares



Test Instruction Recommendations: Classic Bay 1200

Created on/by: 10/11/18; C. Winslow Howe – HHT Design Engineer

Purpose: To create repeatability in test protocol of the stove.

Hopper Fuel: Hopper of the unit should be loaded up with 1 bag of fuel (bag weighing 40lb)

Test Settings: Unit should be set up using a 6in flue, and 120 V wall outlet

High: Toggle switch set to high, FRAP rod pulled to full open and control board set to 2. To make sure board is set to 2 unplug and plug the power cord back into the unit. the control box should flash a blue light two times.

Medium: Toggle switch set to low, FRAP rod set to medium marking and control board set to 1. To make sure board is set to 1 unplug and plug the power cord back into the unit. the control box should flash a blue light one time.

Low: Toggle switch set to low, FRAP rod set to low marking and control board set to 1.

2.1 - Test Data by Run

Run 1 Notes & Results

ASTM E2779 / ASTM E2515 Emissions Results

Manufacturer: Hearth & Home
 Model: CB 1200I-C
 Project No.: 0061PM077E
 Tracking No.: 2332
 Run: 1
 Test Date: 12/18/18

Technician Signature: 

Integrated Test Run	
Particulate Emission Rate	0.78 g/hr
Total Particulate Emissions - E _T	4.69 g
Emissions Factor	0.70 g/kg
CSA B415 Efficiency	63.6% HHV

First Hour Emissions	
Particulate Emission Rate	0.99 g/hr
Total Particulate Emissions - E _T	0.99 g
Emissions Factor	0.41 g/kg

Burn Rate (Composite)	1.12 kg/hr dry
Burn Rate (High)	2.42 kg/hr dry
Burn Rate (Medium)	0.87 kg/hr dry
Burn Rate (Low)	0.85 kg/hr dry
Average Tunnel Temperature	99 degrees F
Avg.Velocity in Dilution Tunnel - v _s	14.12 ft/second
Avg.Flow Rate in Dilution Tunnel - Q _{sd}	9254.3 dscf/hour
Average Δp	0.055 inches H2O
Average ΔH	1.34 inches H2O
Total Time of Test	360 minutes

36.0% Of High
 35.1% Of High

ASTM E2779 / ASTM E2515 Emissions Results

Manufacturer: Hearth & Home
 Model: CB 1200I-C
 Project No.: 0061PM077E
 Tracking No.: 2332
 Run: 1
 Test Date: 12/18/18

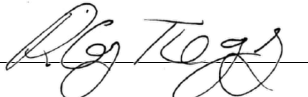
Technician Signature: 

Integrated Test Run	
Particulate Emission Rate	0.85 g/hr
Total Particulate Emissions - E _T	5.13 g
Emissions Factor	0.76 g/kg
CSA B415 Efficiency	63.6% HHV

Uncorrected

First Hour Emissions	
Particulate Emission Rate	0.99 g/hr
Total Particulate Emissions - E _T	0.99 g
Emissions Factor	0.41 g/kg

Burn Rate (Composite)	1.12 kg/hr dry
Burn Rate (High)	2.42 kg/hr dry
Burn Rate (Medium)	0.87 kg/hr dry
Burn Rate (Low)	0.85 kg/hr dry
Average Tunnel Temperature	99 degrees F
Avg. Velocity in Dilution Tunnel - v _s	14.12 ft/second
Avg. Flow Rate in Dilution Tunnel - Q _{sd}	9254.3 dscf/hour
Average Δp	0.055 inches H2O
Average ΔH	1.34 inches H2O
Total Time of Test	360 minutes

36.0% Of High

35.1% Of High

ASTM E2779 / ASTM E2515 Emissions Results

Manufacturer: Hearth & Home
 Model: CB 1200I-C
 Project No.: 0061PM077E
 Tracking No.: 2332
 Run: 1
 Test Date: 12/18/18

Technician Signature: 

	1 st Hour	Sample Train 1	Sample Train 2	Sample	Unit
Total Sample Volume - V_m	9.571	58.023	59.019	N/A	ft ³
Average Gas Meter Temperature	74.72	78.71	79.23		°F
Sample Volume (Std. Conditions) - V_{mstd}	9.374	56.413	57.233		dsf ³
Total Particulates - m_n	1.0	4.7	4.9		mg
Particulate Concentration - C_r/C_s	1.067E-04	8.33E-05	8.56E-05		g/dsf ³
Total Particulate Emissions - E_T	0.99	4.63	4.75		g
Particulate Emission Rate	0.99	0.77	0.79		g/hr
Emissions Factor	0.41	0.69	0.71		g/kg
Delta from Avg. Particulate Emissions		0.06	0.06		g

Quality Checks

Filter Temps < 90 °F	OK	Ambient Temp (55-90°F)	OK
Filter Face Velocity	OK	Negative Probe Weight	OK
Leakage Rate	OK	Pro-Rate Variation	OK
Medium Burn Rate < 50%	OK	Dual Train Comparison	OK

CSA B415.1 Results - Overall & By Category

Manufacturer: Hearth & Home
 Model: CB 1200I-C
 Date: 12/18/18

Run: 1
 Control #: 0061PM077E
 Test Duration: 360

Test Results in Accordance with CSA B415.1-09 - Overall			
	HHV Basis	LHV Basis	
Overall Efficiency	63.6%	67.6%	
Combustion Efficiency	99.5%	99.5%	
Heat Transfer Efficiency	64%	68.0%	
Output Rate (kJ/h)	15,011	14,239	(Btu/h)
Burn Rate (kg/h)	1.12	2.47	(lb/h)
Input (kJ/h)	23,621	22,407	(Btu/h)
Test Load Weight (dry kg)	6.72	14.81	dry lb
MC wet (%)	6.27		
MC dry (%)	6.69		
Particulate (g)	4.69		
CO (g)	52		
Test Duration (h)	6.00		
Emissions	Particulate	CO	
g/MJ Output	0.05	0.58	
g/kg Dry Fuel	0.70	7.71	
g/h	0.78	8.63	
lb/MM Btu Output	0.12	1.34	
Air/Fuel Ratio (A/F)	47.01		

Test Results in Accordance with CSA B415.1-09 - Maximum			
	HHV Basis	LHV Basis	
Overall Efficiency	69.9%	74.5%	
Combustion Efficiency	99.5%	99.5%	
Heat Transfer Efficiency	70%	74.8%	
Output Rate (kJ/h)	35,763	33,925	(Btu/h)
Burn Rate (kg/h)	2.42	5.34	(lb/h)
Input (kJ/h)	51,128	48,501	(Btu/h)
Test Load Weight (dry kg)	2.42	5.34	dry lb
MC wet (%)	6.27		
MC dry (%)	6.69		
Particulate (g)	1.00		
CO (g)	4		
Test Duration (h)	1.00		
Emissions	Particulate	CO	
g/MJ Output	0.03	0.10	
g/kg Dry Fuel	0.41	1.50	
g/h	1.00	3.62	
lb/MM Btu Output	0.06	0.24	
Air/Fuel Ratio (A/F)	22.27		

Test Results in Accordance with CSA B415.1-09 - Medium			
	HHV Basis	LHV Basis	
Overall Efficiency	59.7%	63.6%	
Combustion Efficiency	99.5%	63.9%	
Heat Transfer Efficiency	60%	63.9%	
Output Rate (kJ/h)	10,986	10,421	(Btu/h)
Burn Rate (kg/h)	0.87	1.92	(lb/h)
Input (kJ/h)	18,388	17,443	(Btu/h)
Test Load Weight (dry kg)	1.74	3.84	dry lb
MC wet (%)	6.27		
MC dry (%)	6.69		
Particulate (g)	-		
CO (g)	12		
Test Duration (h)	2.00		
Emissions	Particulate	CO	
g/MJ Output	-	0.54	
g/kg Dry Fuel	-	6.81	
g/h	-	5.93	
lb/MM Btu Output	-	1.26	
Air/Fuel Ratio (A/F)	55.75		

Test Results in Accordance with CSA B415.1-09 - Minimum			
	HHV Basis	LHV Basis	
Overall Efficiency	59.8%	63.7%	
Combustion Efficiency	99.5%	64.0%	
Heat Transfer Efficiency	60%	64.0%	
Output Rate (kJ/h)	10,734	10,182	(Btu/h)
Burn Rate (kg/h)	0.85	1.87	(lb/h)
Input (kJ/h)	17,940	17,018	(Btu/h)
Test Load Weight (dry kg)	2.55	5.62	dry lb
MC wet (%)	6.27		
MC dry (%)	6.69		
Particulate (g)	-		
CO (g)	35		
Test Duration (h)	3.00		
Emissions	Particulate	CO	
g/MJ Output	-	1.10	
g/kg Dry Fuel	-	13.87	
g/h	-	11.80	
lb/MM Btu Output	-	2.55	
Air/Fuel Ratio (A/F)	63.84		

VERSION: 2-2 42/14/2009

Modified to fit this Format

Pellet Heater Conditioning Data - ASTM E2779

Manufacturer: Hearth & Home
 Model: CB 1200I-C
 Tracking No.: 2332
 Project No.: 0061PM077E
 Test Date: Nov - Dec 2018
 Operation Category: Medium

Elapsed Time (hours)	Fuel Added (lbs)	Stack (°F)
0	285.6	194
1	280.5	218
2	275.8	139
3	279.6	165
4	274.2	233
5	270.7	160
6	267.5	155
7	277.3	230
8	271.7	240
9	269.1	114
10	267.1	115
11	276.2	229
12	273.8	235
13	270.8	239
14	269.4	129
15	268.7	112
16	269.4	214
17	264.2	216
18	261.5	119
19	259.3	119
20	257.3	108
21	255.2	121
22	253.1	126
23	266.9	211
24	261.7	214
25	259.1	113
26	256.9	123
27	254.9	113
28	252.9	114
29	250.8	117
30	261.1	234

Pellet Heater Conditioning Data - ASTM E2779

Manufacturer: Hearth & Home
 Model: CB 1200I-C
 Tracking No.: 2332
 Project No.: 0061PM077E
 Test Date: Nov - Dec 2018
 Operation Category: Medium

Elapsed Time (hours)	Fuel Added (lbs)	Stack (°F)
31	255.5	241
32	251.5	198
33	247.7	199
34	245.6	117
35	243.7	119
36	241.9	117
37	266.6	240
38	261.2	239
39	258.6	126
40	256.5	118
41	255.0	98
42	253.7	93
43	290.0	106
44	284.8	215
45	279.3	222
46	277.6	220
47	272.2	225
48	266.7	222
49	261.7	195
50	258.3	180

Pellet Heater Preburn Data - ASTM E2779

Manufacturer: Hearth & Home
 Model: CB 1200I-C
 Tracking No.: 2332
 Project No.: 0061PM077E
 Test Date: 12/18/18

PB Length: 60 min
 Recording Interval: 1 min

Averages:	385	68	-0.04		
-----------	-----	----	-------	--	--

Elapsed Time (min)	Scale Reading	Weight Change	Stack (F)	Ambient (F)	Draft ("H2O)		
0	38.2	-	240	65	-0.03		
1	38.1	-0.1	276	65	-0.03		
2	37.9	-0.2	308	65	-0.04		
3	37.8	-0.1	335	65	-0.04		
4	37.7	-0.1	356	65	-0.04		
5	37.6	-0.1	367	65	-0.04		
6	37.5	-0.1	373	66	-0.04		
7	37.4	-0.1	373	66	-0.04		
8	37.3	-0.1	375	66	-0.04		
9	37.2	-0.1	382	66	-0.04		
10	37.1	-0.1	385	66	-0.04		
11	37.0	-0.1	385	66	-0.04		
12	36.9	-0.1	388	67	-0.04		
13	36.8	-0.1	391	67	-0.04		
14	36.7	-0.1	391	68	-0.04		
15	36.6	-0.1	394	67	-0.04		
16	36.5	-0.1	390	67	-0.04		
17	36.4	-0.1	393	67	-0.04		
18	36.3	-0.1	391	68	-0.04		
19	36.2	-0.1	394	67	-0.05		
20	36.1	-0.1	399	67	-0.04		
21	36.0	-0.1	401	67	-0.05		
22	35.9	-0.1	401	67	-0.04		
23	35.8	-0.1	403	69	-0.04		
24	35.7	-0.1	404	68	-0.04		
25	35.6	-0.1	403	67	-0.04		
26	35.5	-0.1	405	67	-0.05		
27	35.4	-0.1	406	67	-0.04		
28	35.3	-0.1	406	68	-0.04		
29	35.2	-0.1	405	68	-0.04		

Pellet Heater Preburn Data - ASTM E2779

Manufacturer: Hearth & Home
 Model: CB 1200I-C
 Tracking No.: 2332
 Project No.: 0061PM077E
 Test Date: 12/18/18

PB Length: 60 min
 Recording Interval: 1 min

Averages:

385	68	-0.04		
-----	----	-------	--	--

30	35.1	-0.1	403	68	-0.04		
31	35.0	-0.1	406	67	-0.04		
32	35.0	0	402	69	-0.04		
33	34.9	-0.1	406	68	-0.04		
34	34.7	-0.2	408	68	-0.04		
35	34.6	-0.1	410	68	-0.05		
36	34.6	0	373	69	-0.05		
37	34.6	0	339	68	-0.04		
38	33.8	-0.8	337	69	-0.04		
39	30.5	-3.3	372	69	-0.04		
40	34.3	3.8	386	68	-0.04		
41	34.4	0.1	387	68	-0.05		
42	36.0	1.6	370	70	-0.04		
43	35.9	-0.1	383	68	-0.04		
44	35.8	-0.1	387	68	-0.04		
45	35.7	-0.1	389	69	-0.04		
46	35.6	-0.1	388	69	-0.04		
47	35.5	-0.1	391	68	-0.04		
48	35.4	-0.1	394	68	-0.04		
49	35.3	-0.1	394	68	-0.04		
50	35.2	-0.1	396	68	-0.04		
51	35.1	-0.1	397	68	-0.04		
52	35.0	-0.1	399	70	-0.04		
53	34.9	-0.1	399	69	-0.04		
54	34.8	-0.1	402	69	-0.04		
55	34.7	-0.1	405	70	-0.04		
56	34.6	-0.1	403	70	-0.04		
57	34.5	-0.1	402	71	-0.04		
58	34.4	-0.1	405	71	-0.05		
59	34.2	-0.2	409	69	-0.05		
60	34.1	-0.1	410	71	-0.05		

Pellet Heater Test Data - ASTM E2779 / ASTM E2515

Run: 1	Manufacturer: <u>Hearth & Home</u>			High Burn End Time: <u>60</u>
	Model: <u>CB 12001-C</u>			Medium Burn End Time: <u>180</u>
	Tracking No.: <u>2332</u>			Total Sampling Time: <u>360</u> min
	Project No.: <u>0061PM077E</u>			Recording Interval: <u>1</u> min
	Test Date: <u>18-Dec-18</u>			
Beginning Clock Time: <u>10:57</u>	Background Sample Volume: <u>0</u> cubic feet			
Meter Box Y Factor: <u>0.986</u> (1) <u>0.985</u> (2) <u>0</u> (Amb)				
Barometric Pressure: <u>30.01</u> <u>30.02</u> <u>30.02</u> <u>30.02</u> ^{Hg}	Begin	Middle	End	Average

PM Control Modules: <u>0335, 00336</u>	Avg. Tunnel Velocity: <u>14.12</u> ft/sec.	
Dilution Tunnel MW(dry): <u>29.00</u> lb/lb-mole	Initial Tunnel Flow: <u>150.7</u> scfm	
Dilution Tunnel MW(wet): <u>28.78</u> lb/lb-mole	Average Tunnel Flow: <u>154.2</u> scfm	
Dilution Tunnel H2O: <u>2.00</u> percent	Post-Test Leak Check (1): <u>0.000</u> cfm @ <u>10</u> in. Hg	
Dilution Tunnel Static: <u>-0.220</u> ^{H₂O}	Post-Test Leak Check (2): <u>0.000</u> cfm @ <u>7</u> in. Hg	
Tunnel Area: <u>0.1963</u> ft ²	Fuel Moisture (%): <u>6.689</u> Dry Basis <u>6.270</u> Wet Basis	
Pitot Tube Cp: <u>0.99</u>		

Velocity Traverse Data									
	Pt.1	Pt.2	Pt.3	Pt.4	Pt.5	Pt.6	Pt.7	Pt.8	Center
Initial dP	0.038	0.050	0.046	0.036	0.036	0.048	0.050	0.036	0.054
Temp:	116	117	117	117	117	117	117	117	117

V_{strav} 14.23 ft/sec V_{scent} 16.08 ft/sec F_p 0.885

Elapsed Time (min)	Particulate Sampling Data												Fuel Weight (lb)		Temperature Data (°F)							Stack Gas Data			
	Gas Meter 1 (ft ³)	Gas Meter 2 (ft ³)	Sample Rate 1 (cfm)	Sample Rate 2 (cfm)	Orifice dH 1 (H ₂ O)	Meter Temp 1 (°F)	Meter Vacuum 1 (°Hg)	Orifice dH 2 (H ₂ O)	Meter Temp 2 (°F)	Meter Vacuum 2 (°Hg)	Dilution Tunnel (°F)	Tunnel Center dP	Pro. Rate 1	Pro. Rate 2	Scale Reading	Weight Change	Stack	Filter 1	Dryer 1	Filter 2	Dryer 2	Ambient	Draft (H ₂ O)	CO ₂ (%)	CO (%)
0	0.000	0.000			0.72	70	1.49	0.84	71	1.10	118	0.055			34.1		408	67	67	68	67	70	-0.049	5.26	0.005
1	0.149	0.159	0.15	0.16	1.36	70	2.02	1.12	71	1.10	118	0.054	96	101	34.0	-0.1	409	68	67	69	67	71	-0.049	5.54	0.006
2	0.309	0.323	0.16	0.16	1.36	70	2.02	1.11	71	1.10	118	0.055	102	103	33.9	-0.1	408	69	68	70	67	70	-0.048	5.28	0.005
3	0.469	0.488	0.16	0.17	1.35	70	2.02	1.11	71	1.10	119	0.053	104	106	33.8	-0.1	410	69	68	71	67	71	-0.048	5.65	0.006
4	0.629	0.652	0.16	0.16	1.34	70	2.02	1.11	71	1.10	119	0.054	103	104	33.8	0.0	411	69	68	71	67	72	-0.050	5.37	0.005
5	0.789	0.815	0.16	0.16	1.34	70	2.02	1.10	71	1.10	119	0.054	103	104	33.6	-0.2	413	70	68	72	67	71	-0.048	5.88	0.006
6	0.948	0.978	0.16	0.16	1.34	70	2.01	1.11	71	1.10	119	0.054	103	104	33.6	0.0	411	70	68	72	68	72	-0.049	4.86	0.006
7	1.108	1.142	0.16	0.16	1.35	71	2.02	1.11	72	1.10	119	0.053	104	105	33.5	-0.1	411	71	68	73	68	71	-0.048	5.38	0.007
8	1.268	1.305	0.16	0.16	1.34	71	2.02	1.10	72	1.10	119	0.054	103	103	33.4	-0.1	415	71	69	73	68	70	-0.048	5.67	0.006
9	1.428	1.470	0.16	0.17	1.34	71	2.01	1.10	72	1.10	119	0.053	104	106	33.3	-0.1	417	72	69	73	68	72	-0.049	5.97	0.006
10	1.587	1.633	0.16	0.16	1.34	71	2.01	1.10	72	1.10	120	0.053	104	104	33.2	-0.1	414	72	69	74	68	73	-0.048	5.34	0.005
11	1.746	1.796	0.16	0.16	1.34	71	2.00	1.10	72	1.10	119	0.054	103	103	33.1	-0.1	410	72	69	74	68	73	-0.046	4.42	0.005
12	1.906	1.959	0.16	0.16	1.34	71	2.00	1.10	72	1.10	120	0.052	105	105	33.0	-0.1	409	73	69	74	68	71	-0.047	5.48	0.006
13	2.066	2.122	0.16	0.16	1.34	72	2.01	1.09	73	1.10	120	0.052	105	105	32.9	-0.1	410	73	69	75	69	72	-0.048	5.53	0.005
14	2.225	2.286	0.16	0.16	1.33	72	2.00	1.09	73	1.10	120	0.053	103	105	32.8	-0.1	410	73	70	75	69	71	-0.048	6.00	0.006
15	2.384	2.448	0.16	0.16	1.32	72	2.01	1.08	73	1.10	120	0.053	103	104	32.7	-0.1	412	74	70	75	69	72	-0.047	5.59	0.006
16	2.543	2.611	0.16	0.16	1.33	72	1.99	1.09	73	1.10	120	0.054	103	103	32.6	-0.1	413	74	70	75	69	73	-0.047	6.06	0.007
17	2.702	2.773	0.16	0.16	1.32	72	2.01	1.09	73	1.10	120	0.053	103	104	32.5	-0.1	414	74	70	76	69	72	-0.047	5.76	0.007
18	2.861	2.936	0.16	0.16	1.33	73	2.00	1.09	74	1.10	120	0.053	103	104	32.4	-0.1	412	74	71	76	69	71	-0.046	4.68	0.007
19	3.020	3.100	0.16	0.16	1.33	73	1.99	1.08	74	1.10	120	0.053	103	105	32.3	-0.1	413	75	71	76	70	71	-0.048	6.10	0.009
20	3.180	3.262	0.16	0.16	1.33	73	1.99	1.08	74	1.10	120	0.053	104	103	32.2	-0.1	413	75	71	76	70	72	-0.047	5.37	0.008
21	3.339	3.425	0.16	0.16	1.33	73	1.99	1.09	74	1.10	120	0.054	102	103	32.1	-0.1	414	75	71	77	70	72	-0.047	6.15	0.008
22	3.498	3.587	0.16	0.16	1.33	73	2.00	1.09	75	1.10	120	0.053	103	103	32.0	-0.1	413	75	71	77	70	72	-0.049	4.57	0.008
23	3.658	3.750	0.16	0.16	1.32	74	2.00	1.09	75	1.10	120	0.054	103	103	32.0	0.0	412	76	72	77	70	72	-0.048	5.56	0.006
24	3.817	3.914	0.16	0.16	1.33	74	2.01	1.09	75	1.10	120	0.054	102	103	31.9	-0.1	410	76	72	77	71	72	-0.048	5.02	0.006
25	3.977	4.076	0.16	0.16	1.33	74	2.00	1.08	75	1.10	120	0.053	104	103	31.8	-0.1	411	76	72	77	71	73	-0.048	5.25	0.010
26	4.136	4.238	0.16	0.16	1.33	74	2.00	1.08	75	1.10	120	0.053	103	103	31.7	-0.1	409	76	72	77	71	73	-0.048	5.18	0.005
27	4.295	4.401	0.16	0.16	1.32	74	1.99	1.08	76	1.10	120	0.054	102	103	31.6	-0.1	407	76	72	78	71	73	-0.047	4.80	0.006
28	4.454	4.565	0.16	0.16	1.32	75	2.00	1.08	76	1.10	120	0.054	102	103	31.5	-0.1	409	77	73	78	71	73	-0.048	5.56	0.006
29	4.614	4.727	0.16	0.16	1.33	75	2.00	1.09	76	1.10	120	0.055	102	101	31.4	-0.1	409	77	73	78	71	74	-0.048	5.38	0.006
30	4.773	4.890	0.16	0.16	1.32	75	2.01	1.08	76	1.10	120	0.054	102	103	31.3	-0.1	412	77	73	78	71	73	-0.048	5.77	0.005
31	4.933	5.052	0.16	0.16	1.33	75	2.01	1.08	77	1.10	121	0.054	103	102	31.2	-0.1	415	77	73	78	72	73	-0.048	6.19	0.012
32	5.092	5.215	0.16	0.16	1.33	75	2.00	1.09	77	1.10	121	0.054	102	103	31.1	-0.1	415	77	73	78	72	74	-0.048	5.67	0.016
33	5.252	5.379	0.16	0.16	1.32	76	2.00	1.08	77	1.10	121	0.055	102	102	31.0	-0.1	417	77	74	78	72	73	-0.048	5.88	0.010
34	5.412	5.542	0.16	0.16	1.32	76	2.00	1.08	77	1.10	121	0.054	102	103	30.9	-0.1	417	77	74	78	72	72	-0.049	5.69	0.008
35	5.572	5.704	0.16	0.16	1.32	76	2.01	1.09	77	1.10	121	0.054	102	102	30.8	-0.1	415	77	74	78	72	74	-0.048	5.26	0.006
36	5.732	5.867	0.16	0.16	1.32	76	2.01	1.09	77	1.10	121	0.055	102	102	30.7	-0.1	416	77	74	78	72	74	-0.049	5.94	0.006
37	5.892	6.030	0.16	0.16	1.32	76	2.00	1.09	78	1.10	121	0.054	102	102	30.6	-0.1	414	78	74	79	72	74	-0.048	4.95	0.006
38	6.051	6.194	0.16	0.16	1.32	76	2.00	1.09	78	1.10	121	0.053	103	104	30.5	-0.1	414	78	74	79	73	74	-0.047	5.21	0.005
39	6.211	6.357	0.16	0.16	1.32	77	2.01	1.08	78	1.10	121	0.055	101	101	30.4	-0.1	417	78	74	79	73	73	-0.049	5.83	0.006
40	6.370	6.519	0.16	0.16	1.32	77	2.01	1.08	78	1.10	121	0.054	102	102	30.3	-0.1	415	78	75	79	73	73	-0.048	5.63	0.006
41	6.530	6.682	0.16	0.16	1.33	77	2.00	1.09	78	1.10	121	0.054	102	102	30.2	-0.1	413	78	75	79	73	73	-0.047	4.87	0.007
42	6.690	6.846	0.16	0.16	1.32	77	2.01	1.08	78	1.10	121	0.055	101	102	30.2	0.0	414	78	75	79	73	73	-0.049	5.48	0.006
43	6.850	7.010	0.16	0.16	1.33	77	2.01	1.08	79	1.10	121	0.055	101	102	30.1	-0.1	414	78	75	79	73	73	-0.049	5.85	0.009
44	7.010	7.172	0.16	0.16	1.32	77	2.00	1.08	79	1.10	121	0.054	102	102	30.0	-0.1	414	78	75	79	73	73	-0.049	5.40	0.005
45	7.170	7.335	0.16	0.16	1.33	77	2.00	1.08	79	1.10	121	0.054	102	102	29.9	-0.1	415	78	75	79	74	74	-0.048	5.73	0.006
46	7.330	7.498	0.16	0.16	1.32	78	2.01	1.08	79	1.10	121	0.054	102	102	29.8	-0.1	416	78	76	79	74				

Pellet Heater Test Data - ASTM E2779 / ASTM E2515

Run: 1

Manufacturer: Hearth & Home High Burn End Time: 60
 Model: CB 12001-C Medium Burn End Time: 180
 Tracking No.: 2332 Total Sampling Time: 360 min
 Project No.: 0061PM077E Recording Interval: 1 min
 Test Date: 18-Dec-18
 Beginning Clock Time: 10:57 Background Sample Volume: 0 cubic feet

Meter Box Y Factor: 0.986 (1) 0.985 (2) 0 (Amb)

Barometric Pressure: Begin Middle End Average
30.01 30.02 30.02 30.02 "Hg

PM Control Modules: 0335, 00336
 Dilution Tunnel MW(dry): 29.00 lb/lb-mole
 Dilution Tunnel MW(wet): 28.78 lb/lb-mole
 Dilution Tunnel H₂O: 2.00 percent
 Dilution Tunnel Static: -0.220 H₂O
 Tunnel Area: 0.1963 ft²
 Pitot Tube Cp: 0.99

Avg. Tunnel Velocity: 14.12 ft/sec.
 Initial Tunnel Flow: 150.7 scfm
 Average Tunnel Flow: 154.2 scfm
 Post-Test Leak Check (1): 0.000 cfm @ 10 in. Hg
 Post-Test Leak Check (2): 0.000 cfm @ 7 in. Hg
 Fuel Moisture (%): 6.689 Dry Basis 6.270 Wet Basis

Velocity Traverse Data									
	Pt.1	Pt.2	Pt.3	Pt.4	Pt.5	Pt.6	Pt.7	Pt.8	Center
Initial dP	0.038	0.050	0.046	0.036	0.036	0.048	0.050	0.036	0.054
Temp:	116	117	117	117	117	117	117	117	117
V _{strav}		14.23			ft/sec		V _{scent}		16.08
						F _p		0.885	

Elapsed Time (min)	Particulate Sampling Data											Fuel Weight (lb)		Temperature Data (°F)						Stack Gas Data					
	Gas Meter 1 (ft ³)	Gas Meter 2 (ft ³)	Sample Rate 1 (cfm)	Sample Rate 2 (cfm)	Orifice dH 1 (H ₂ O)	Meter Temp 1 (°F)	Meter Vacuum 1 (°Hg)	Orifice dH 2 (H ₂ O)	Meter Temp 2 (°F)	Meter Vacuum 2 (°Hg)	Dilution Tunnel (°F)	Tunnel Center dP	Pro. Rate 1	Pro. Rate 2	Scale Reading	Weight Change	Stack	Filter 1	Dryer 1	Filter 2	Dryer 2	Ambient	Draft (H ₂ O)	CO ₂ (%)	CO (%)
49	7.810	7.989	0.16	0.16	1.33	78	2.01	1.08	79	1.10	121	0.054	101	103	29.5	-0.1	415	78	76	79	74	74	-0.048	5.07	0.007
50	7.970	8.152	0.16	0.16	1.32	78	2.01	1.09	80	1.10	122	0.053	103	103	29.4	-0.1	417	78	76	79	74	74	-0.048	5.66	0.008
51	8.130	8.315	0.16	0.16	1.32	78	2.00	1.09	80	1.10	122	0.054	102	102	29.3	-0.1	419	79	76	79	74	73	-0.049	5.92	0.006
52	8.290	8.478	0.16	0.16	1.32	78	2.01	1.08	80	1.10	121	0.054	102	102	29.2	-0.1	416	79	76	79	74	74	-0.048	5.24	0.006
53	8.450	8.642	0.16	0.16	1.32	78	2.01	1.08	80	1.10	122	0.054	102	103	29.1	-0.1	419	79	77	80	74	74	-0.049	5.91	0.005
54	8.610	8.805	0.16	0.16	1.32	79	2.01	1.09	80	1.10	122	0.054	102	102	29.0	-0.1	418	79	77	80	74	74	-0.049	5.48	0.008
55	8.770	8.968	0.16	0.16	1.32	79	2.01	1.08	80	1.10	122	0.052	104	104	28.9	-0.1	418	79	77	80	75	74	-0.049	5.64	0.008
56	8.931	9.132	0.16	0.16	1.32	79	2.01	1.08	80	1.10	122	0.054	103	103	28.8	-0.1	415	79	77	80	75	75	-0.048	4.80	0.007
57	9.090	9.295	0.16	0.16	1.33	79	2.01	1.09	80	1.10	122	0.055	100	101	28.7	-0.1	418	79	77	80	75	75	-0.049	5.76	0.007
58	9.251	9.458	0.16	0.16	1.32	79	2.01	1.08	81	1.10	122	0.054	103	102	28.6	-0.1	418	79	77	80	75	75	-0.049	5.63	0.006
59	9.411	9.623	0.16	0.16	1.33	79	2.02	1.08	81	1.10	122	0.054	102	103	28.5	-0.1	419	79	77	80	75	74	-0.048	5.01	0.006
60	9.571	9.786	0.16	0.16	1.32	79	2.01	1.08	81	1.10	122	0.054	102	102	28.4	-0.1	421	79	78	80	75	74	-0.049	5.91	0.009
61	9.734	9.949	0.16	0.16	1.33	79	1.99	1.09	81	1.10	120	0.055	103	101	28.3	-0.1	412	79	78	80	75	75	-0.048	5.87	0.010
62	9.894	10.112	0.16	0.16	1.33	79	2.00	1.09	81	1.10	117	0.055	101	101	28.2	-0.1	405	80	78	80	75	73	-0.047	4.20	0.005
63	10.055	10.276	0.16	0.16	1.32	79	2.00	1.09	81	1.10	116	0.055	101	101	28.2	0.0	398	80	78	80	75	73	-0.047	3.96	0.004
64	10.216	10.440	0.16	0.16	1.33	80	2.01	1.09	81	1.10	115	0.055	101	101	28.1	-0.1	393	80	78	80	75	73	-0.047	3.83	0.004
65	10.376	10.604	0.16	0.16	1.33	80	1.99	1.08	81	1.10	114	0.054	101	102	28.1	0.0	387	80	78	80	75	74	-0.046	3.29	0.004
66	10.537	10.767	0.16	0.16	1.33	80	2.00	1.08	81	1.10	113	0.055	101	100	28.1	0.0	381	80	78	79	76	73	-0.045	3.13	0.004
67	10.698	10.930	0.16	0.16	1.33	80	2.00	1.09	81	1.10	113	0.053	103	102	28.0	-0.1	374	80	78	79	76	73	-0.045	2.32	0.008
68	10.859	11.094	0.16	0.16	1.33	80	2.01	1.09	81	1.10	112	0.053	103	103	28.0	0.0	364	80	78	79	76	74	-0.043	1.99	0.022
69	11.020	11.258	0.16	0.16	1.32	80	2.01	1.09	81	1.10	111	0.053	102	102	27.9	-0.1	361	79	79	79	76	73	-0.043	2.69	0.005
70	11.181	11.422	0.16	0.16	1.33	80	2.00	1.08	81	1.10	110	0.055	100	101	27.9	0.0	354	79	79	79	76	73	-0.042	2.63	0.003
71	11.342	11.586	0.16	0.16	1.33	80	2.00	1.09	82	1.10	109	0.055	100	100	27.9	0.0	346	79	79	79	76	72	-0.042	2.24	0.005
72	11.503	11.749	0.16	0.16	1.33	80	2.00	1.08	82	1.10	108	0.054	101	100	27.8	-0.1	342	79	79	79	76	73	-0.041	2.58	0.006
73	11.663	11.913	0.16	0.16	1.33	80	1.99	1.09	82	1.10	108	0.055	100	100	27.8	0.0	335	79	79	79	76	73	-0.040	2.65	0.002
74	11.824	12.077	0.16	0.16	1.33	80	2.00	1.09	82	1.10	107	0.054	101	101	27.8	0.0	326	79	78	79	75	72	-0.039	2.24	0.004
75	11.986	12.241	0.16	0.16	1.33	80	2.00	1.09	82	1.10	106	0.054	102	101	27.7	-0.1	320	79	77	78	74	72	-0.038	1.83	0.014
76	12.147	12.405	0.16	0.16	1.32	80	2.00	1.09	82	1.10	105	0.055	100	100	27.7	0.0	317	78	76	78	73	72	-0.039	1.84	0.013
77	12.308	12.569	0.16	0.16	1.32	81	1.99	1.09	82	1.10	104	0.054	101	101	27.7	0.0	312	78	75	78	73	72	-0.038	2.22	0.005
78	12.469	12.733	0.16	0.16	1.32	81	2.00	1.08	82	1.10	104	0.055	100	100	27.6	-0.1	305	78	75	78	72	72	-0.038	1.29	0.018
79	12.630	12.897	0.16	0.16	1.32	81	2.00	1.08	82	1.10	103	0.054	101	101	27.6	0.0	307	78	75	78	72	71	-0.038	2.54	0.005
80	12.791	13.061	0.16	0.16	1.32	81	1.99	1.09	82	1.10	103	0.055	100	100	27.5	-0.1	301	78	75	78	72	71	-0.036	2.67	0.003
81	12.952	13.225	0.16	0.16	1.33	81	2.00	1.09	82	1.10	102	0.055	100	100	27.5	0.0	295	78	75	78	72	71	-0.035	1.70	0.029
82	13.113	13.389	0.16	0.16	1.33	81	1.99	1.09	82	1.10	101	0.054	100	100	27.5	0.0	290	78	75	78	71	71	-0.035	1.88	0.006
83	13.275	13.554	0.16	0.17	1.33	81	1.99	1.09	82	1.10	101	0.055	100	100	27.5	0.0	289	77	75	77	71	70	-0.034	2.15	0.009
84	13.436	13.718	0.16	0.16	1.33	81	2.00	1.08	82	1.10	100	0.055	99	99	27.4	-0.1	284	77	75	77	71	70	-0.034	2.29	0.007
85	13.597	13.881	0.16	0.16	1.33	81	1.99	1.09	82	1.10	100	0.056	98	98	27.4	0.0	280	77	74	77	71	70	-0.033	1.94	0.015
86	13.759	14.046	0.16	0.16	1.33	81	2.00	1.09	82	1.10	99	0.055	100	100	27.4	0.0	276	77	74	77	71	70	-0.032	1.44	0.022
87	13.920	14.210	0.16	0.16	1.33	81	2.00	1.09	82	1.10	99	0.055	99	99	27.3	-0.1	275	77	74	76	71	69	-0.034	1.81	0.007
88	14.082	14.374	0.16	0.16	1.33	81	2.00	1.09	82	1.10	99	0.055	100	99	27.3	0.0	273	76	74	76	71	69	-0.032	2.19	0.006
89	14.243	14.539	0.16	0.16	1.34	81	1.99	1.09	82	1.10	98	0.056	98	99	27.3	0.0	267	76	74	76	71	69	-0.032	1.44	0.026
90	14.405	14.703	0.16	0.16	1.34	81	1.99	1.09	82	1.10	98	0.055	100	99	27.2	-0.1	263	76	74	76	70	69	-0.031	1.45	0.029
91	14.566	14.868	0.16	0.17	1.34	81	2.00	1.08	82	1.10	97	0.056	98	99	27.2	0.0	261	76	74	76	70	68	-0.031	1.79	0.015
92	14.728	15.032	0.16	0.16	1.33	81	2.00	1.09	82	1.10	96	0.056	98	98	27.2	0.0	259	76	74	75	70	68	-0.032	1.84	0.017
93	14.890	15.196	0.16	0.16	1.33	81	1.99	1.09	82	1.10	95	0.055	100	99	27.1	-0.1	256	75	74	75	70	68	-0.031	1.74	0.017
94	15.052	15.360	0.16	0.16	1.33	81	1.99	1.09	82	1.10	95	0.055	100	99	27.1	0.0	256	75	74	75	70	68	-0.030	1.81	0.014
95	15.213	15.525	0.16	0.17	1.34	81	2.00	1.10	81	1.10	95	0.055	99	100	27.1	0.0	258	75	74	75	70	68	-0.031	2.07	0.

Pellet Heater Test Data - ASTM E2779 / ASTM E2515

Run: 1

Manufacturer: Hearth & Home High Burn End Time: 60
 Model: CB 12001-C Medium Burn End Time: 180
 Tracking No.: 2332 Total Sampling Time: 360 min
 Project No.: 0061PM077E Recording Interval: 1 min
 Test Date: 18-Dec-18
 Beginning Clock Time: 10:57 Background Sample Volume: 0 cubic feet

Meter Box Y Factor: 0.986 (1) 0.985 (2) 0 (Amb)

Barometric Pressure: Begin Middle End Average
30.01 30.02 30.02 30.02 Hg

PM Control Modules: 0335, 00336

Dilution Tunnel MW(dry): 29.00 lb/lb-mole
 Dilution Tunnel MW(wet): 28.78 lb/lb-mole
 Dilution Tunnel H2O: 2.00 percent
 Dilution Tunnel Static: -0.220 H₂O
 Tunnel Area: 0.1963 ft²
 Pitot Tube Cp: 0.99

Avg. Tunnel Velocity: 14.12 ft/sec.
 Initial Tunnel Flow: 150.7 scfm
 Average Tunnel Flow: 154.2 scfm
 Post-Test Leak Check (1): 0.000 cfm @ 10 in. Hg
 Post-Test Leak Check (2): 0.000 cfm @ 7 in. Hg
 Fuel Moisture (%): 6.689 Dry Basis 6.270 Wet Basis

Velocity Traverse Data										
	Pt.1	Pt.2	Pt.3	Pt.4	Pt.5	Pt.6	Pt.7	Pt.8	Center	
Initial dP	0.038	0.050	0.046	0.036	0.036	0.048	0.050	0.036	0.054	
Temp:	116	117	117	117	117	117	117	117	117	
V _{strav}		14.23			ft/sec		V _{scent}		16.08	
							F _p		0.885	

Elapsed Time (min)	Particulate Sampling Data												Fuel Weight (lb)		Temperature Data (°F)						Stack Gas Data				
	Gas Meter 1 (ft ³)	Gas Meter 2 (ft ³)	Sample Rate 1 (cfm)	Sample Rate 2 (cfm)	Orifice dH 1 (H ₂ O)	Meter Temp 1 (°F)	Meter Vacuum 1 (H ₂ O)	Orifice dH 2 (H ₂ O)	Meter Temp 2 (°F)	Meter Vacuum 2 (H ₂ O)	Dilution Tunnel (°F)	Tunnel Center dP	Pro. Rate 1	Pro. Rate 2	Scale Reading	Weight Change	Stack	Filter 1	Dryer 1	Filter 2	Dryer 2	Ambient	Draft (H ₂ O)	CO ₂ (%)	CO (%)
98	15.699	16.018	0.16	0.16	1.34	81	2.00	1.09	81	1.10	94	0.055	99	99	27.0	0.0	253	74	73	74	70	68	-0.031	2.01	0.012
99	15.861	16.182	0.16	0.16	1.34	81	2.00	1.09	81	1.10	94	0.056	99	98	27.0	0.0	251	74	73	74	70	68	-0.030	1.77	0.011
100	16.022	16.347	0.16	0.17	1.33	80	2.00	1.09	81	1.10	94	0.055	99	100	26.9	-0.1	248	74	73	74	70	68	-0.031	1.82	0.010
101	16.184	16.511	0.16	0.16	1.34	80	1.99	1.09	81	1.10	93	0.054	100	100	26.9	0.0	248	74	73	74	70	68	-0.029	1.95	0.017
102	16.346	16.676	0.16	0.16	1.34	80	2.00	1.09	81	1.10	93	0.056	99	99	26.9	0.0	248	74	73	74	70	67	-0.030	1.77	0.014
103	16.508	16.841	0.16	0.17	1.34	80	2.00	1.09	81	1.10	93	0.055	100	100	26.9	0.0	250	74	73	74	70	67	-0.030	2.39	0.006
104	16.670	17.005	0.16	0.16	1.33	80	2.00	1.09	81	1.10	93	0.055	100	99	26.8	-0.1	251	74	73	74	69	67	-0.031	2.57	0.008
105	16.831	17.169	0.16	0.16	1.33	80	2.00	1.08	81	1.10	93	0.055	99	99	26.8	0.0	246	74	73	74	69	67	-0.030	1.76	0.020
106	16.993	17.333	0.16	0.16	1.34	80	2.00	1.09	81	1.10	93	0.054	100	100	26.8	0.0	245	73	73	73	69	67	-0.030	1.08	0.072
107	17.155	17.497	0.16	0.16	1.34	80	2.00	1.09	81	1.10	93	0.054	100	100	26.8	0.0	247	73	73	73	69	67	-0.030	2.53	0.006
108	17.317	17.662	0.16	0.16	1.34	80	1.99	1.09	81	1.10	93	0.057	98	98	26.8	0.0	249	73	73	73	69	67	-0.030	2.38	0.008
109	17.479	17.826	0.16	0.16	1.34	80	1.99	1.09	80	1.10	93	0.055	100	99	26.7	-0.1	249	73	72	73	69	67	-0.031	2.41	0.007
110	17.640	17.992	0.16	0.17	1.34	80	1.99	1.09	80	1.10	93	0.056	98	99	26.7	0.0	250	73	72	73	69	67	-0.030	2.25	0.011
111	17.802	18.155	0.16	0.16	1.34	80	2.00	1.08	80	1.10	93	0.055	100	99	26.7	0.0	249	73	72	73	69	67	-0.030	2.01	0.016
112	17.964	18.319	0.16	0.16	1.34	80	2.00	1.09	80	1.10	92	0.055	99	99	26.7	0.0	248	73	72	73	69	67	-0.030	1.99	0.014
113	18.126	18.484	0.16	0.17	1.35	80	1.99	1.09	80	1.10	92	0.055	99	100	26.6	-0.1	248	73	72	73	69	67	-0.030	1.91	0.018
114	18.288	18.648	0.16	0.16	1.34	80	2.00	1.09	80	1.10	92	0.055	99	99	26.6	0.0	245	73	72	73	69	67	-0.030	1.44	0.014
115	18.450	18.812	0.16	0.16	1.34	80	2.00	1.09	80	1.10	92	0.054	100	100	26.6	0.0	243	73	72	73	69	67	-0.029	1.46	0.014
116	18.612	18.977	0.16	0.16	1.34	80	1.99	1.09	80	1.10	92	0.054	100	101	26.5	-0.1	244	72	72	73	69	67	-0.030	2.23	0.007
117	18.774	19.142	0.16	0.16	1.35	80	2.00	1.09	80	1.10	92	0.054	100	101	26.5	0.0	241	72	72	73	69	67	-0.029	1.72	0.012
118	18.936	19.305	0.16	0.16	1.35	80	1.99	1.09	80	1.10	92	0.055	99	98	26.5	0.0	243	72	72	73	69	67	-0.030	1.89	0.010
119	19.097	19.469	0.16	0.16	1.34	80	2.00	1.09	80	1.10	92	0.054	100	100	26.4	-0.1	242	72	72	73	69	67	-0.028	1.80	0.008
120	19.259	19.634	0.16	0.16	1.35	80	1.99	1.09	80	1.10	91	0.056	98	99	26.4	0.0	242	72	72	73	69	67	-0.030	1.73	0.020
121	19.421	19.798	0.16	0.16	1.34	80	2.00	1.09	80	1.10	91	0.055	99	99	26.4	0.0	244	72	72	72	69	67	-0.029	2.85	0.005
122	19.583	19.962	0.16	0.16	1.35	80	2.00	1.09	80	1.10	92	0.055	99	99	26.4	0.0	246	72	72	73	69	67	-0.031	2.08	0.018
123	19.745	20.127	0.16	0.16	1.34	80	1.99	1.09	80	1.10	92	0.055	99	100	26.3	-0.1	248	72	72	72	69	67	-0.031	2.20	0.007
124	19.907	20.291	0.16	0.16	1.34	80	1.99	1.09	80	1.10	92	0.055	99	99	26.3	0.0	247	72	71	72	69	67	-0.030	1.83	0.009
125	20.068	20.455	0.16	0.16	1.35	79	1.99	1.08	80	1.10	92	0.055	99	99	26.3	0.0	247	72	71	72	69	67	-0.030	1.97	0.011
126	20.230	20.619	0.16	0.16	1.34	79	1.99	1.09	80	1.10	92	0.056	99	98	26.2	-0.1	247	72	71	72	69	67	-0.030	1.80	0.010
127	20.391	20.783	0.16	0.16	1.34	79	1.99	1.09	80	1.10	92	0.055	99	99	26.2	0.0	247	72	71	72	69	67	-0.030	1.80	0.013
128	20.553	20.948	0.16	0.16	1.34	79	2.00	1.09	79	1.10	92	0.055	100	100	26.2	0.0	249	72	71	72	69	67	-0.030	2.44	0.008
129	20.715	21.112	0.16	0.16	1.34	79	1.99	1.09	80	1.10	92	0.055	100	99	26.1	-0.1	250	72	71	72	69	68	-0.031	2.25	0.008
130	20.877	21.277	0.16	0.17	1.35	79	1.99	1.09	79	1.10	92	0.055	100	100	26.1	0.0	253	72	71	72	68	67	-0.030	2.54	0.012
131	21.038	21.441	0.16	0.16	1.35	79	2.00	1.09	79	1.10	92	0.054	100	100	26.0	-0.1	253	72	71	72	68	68	-0.031	2.30	0.015
132	21.200	21.605	0.16	0.16	1.35	79	2.00	1.09	79	1.10	92	0.055	100	99	26.0	0.0	254	72	71	72	68	68	-0.031	2.47	0.007
133	21.362	21.769	0.16	0.16	1.34	79	2.00	1.09	79	1.10	92	0.053	102	101	26.0	0.0	250	72	71	72	68	68	-0.030	1.48	0.014
134	21.524	21.933	0.16	0.16	1.35	79	2.00	1.09	79	1.10	92	0.053	102	101	25.9	-0.1	248	72	71	72	68	68	-0.030	1.68	0.015
135	21.685	22.097	0.16	0.16	1.35	79	1.99	1.09	79	1.10	91	0.055	99	99	25.9	0.0	245	72	71	72	68	68	-0.030	1.50	0.029
136	21.847	22.262	0.16	0.16	1.35	79	2.00	1.09	79	1.10	91	0.054	100	101	25.9	0.0	247	72	71	72	68	68	-0.030	1.86	0.008
137	22.009	22.426	0.16	0.16	1.35	79	1.99	1.09	79	1.10	91	0.054	100	100	25.9	0.0	245	72	71	72	68	68	-0.031	2.14	0.007
138	22.170	22.591	0.16	0.17	1.34	79	2.00	1.08	79	1.10	91	0.054	100	101	25.8	-0.1	243	72	70	72	68	68	-0.029	1.86	0.009
139	22.332	22.754	0.16	0.16	1.35	79	1.99	1.09	79	1.10	91	0.055	100	99	25.8	0.0	243	72	70	72	68	68	-0.029	1.84	0.021
140	22.494	22.918	0.16	0.16	1.34	79	1.99	1.09	79	1.10	90	0.054	100	100	25.8	0.0	240	72	70	72	68	68	-0.028	1.49	0.025
141	22.655	23.083	0.16	0.16	1.35	79	1.99	1.08	79	1.10	90	0.054	100	101	25.8	0.0	239	72	70	72	68	68	-0.029	1.48	0.036
142	22.817	23.246	0.16	0.16	1.35	79	1.99	1.09	79	1.10	90	0.055	99	98	25.7	-0.1	237	72	70	72	68	68	-0.029	1.46	0.015
143	22.979	23.411	0.16	0.17	1.34	79	1.99	1.08	79	1.10	90	0.055	99	100	25.7	0.0	238	72	70	72	68	68	-0.028	1.75	0.013
144	23.140	23.575	0.16	0.16	1.35	79	2.00	1.09	79	1.10	90	0.056	98	98	25.7	0.0	239	72	70	72	68	68	-0.029	1.94	0.019
145	23.302	23.739	0.16	0.16	1.34	79	2.00	1.09	79	1.10															

Pellet Heater Test Data - ASTM E2779 / ASTM E2515

Run: **1**

Manufacturer: Hearth & Home
Model: CB 1200I-C
Tracking No.: 2332
Project No.: 0061PM077E
Test Date: 18-Dec-18

High Burn End Time: 60
Medium Burn End Time: 180
Total Sampling Time: 360 min
Recording Interval: 1 min

Beginning Clock Time: 10:57 Background Sample Volume: 0 cubic feet

Meter Box Y Factor: 0.986 (1) 0.985 (2) 0 (Amb)

Barometric Pressure: Begin Middle End Average
30.01 30.02 30.02 30.02 [°]Hg

PM Control Modules: 0335, 00336

Dilution Tunnel MW(dry): 29.00 lb/lb-mole
Dilution Tunnel MW(wet): 28.78 lb/lb-mole
Dilution Tunnel H₂O: 2.00 percent
Dilution Tunnel Static: -0.220 [°]H₂O
Tunnel Area: 0.1963 ft²
Pitot Tube Cp: 0.99

Avg. Tunnel Velocity: 14.12 ft/sec.
Initial Tunnel Flow: 150.7 scfm
Average Tunnel Flow: 154.2 scfm
Post-Test Leak Check (1): 0.000 cfm @ 10 in. Hg
Post-Test Leak Check (2): 0.000 cfm @ 7 in. Hg
Fuel Moisture (%): 6.689 Dry Basis 6.270 Wet Basis

Velocity Traverse Data									
	Pt.1	Pt.2	Pt.3	Pt.4	Pt.5	Pt.6	Pt.7	Pt.8	Center
Initial dP	<u>0.038</u>	<u>0.050</u>	<u>0.046</u>	<u>0.036</u>	<u>0.036</u>	<u>0.048</u>	<u>0.050</u>	<u>0.036</u>	<u>0.054</u>
Temp:	<u>116</u>	<u>117</u>	<u>117</u>	<u>117</u>	<u>117</u>	<u>117</u>	<u>117</u>	<u>117</u>	<u>117</u>
V _{strav}	<u>14.23</u> ft/sec			<u>16.08</u> ft/sec		F _p <u>0.885</u>			

Elapsed Time (min)	Particulate Sampling Data												Fuel Weight (lb)		Temperature Data (°F)						Stack Gas Data				
	Gas Meter 1 (ft ³)	Gas Meter 2 (ft ³)	Sample Rate 1 (cfm)	Sample Rate 2 (cfm)	Orifice dH 1 (°H ₂ O)	Meter Temp 1 (°F)	Meter Vacuum 1 (°Hg)	Orifice dH 2 (°H ₂ O)	Meter Temp 2 (°F)	Meter Vacuum 2 (°Hg)	Dilution Tunnel (°F)	Tunnel Center dP	Pro. Rate 1	Pro. Rate 2	Scale Reading	Weight Change	Stack	Filter 1	Dryer 1	Filter 2	Dryer 2	Ambient	Draft (°H ₂ O)	CO ₂ (%)	CO (%)
147	23.625	24.067	0.16	0.16	1.35	79	1.99	1.09	79	1.10	91	0.055	100	99	25.6	-0.1	239	72	70	72	68	68	-0.029	2.05	0.015
148	23.787	24.231	0.16	0.16	1.35	79	1.99	1.09	79	1.10	91	0.055	100	99	25.6	0.0	238	72	70	72	68	68	-0.029	1.55	0.026
149	23.948	24.396	0.16	0.16	1.34	79	2.00	1.09	79	1.10	91	0.055	99	100	25.6	0.0	242	72	70	72	68	68	-0.029	2.11	0.017
150	24.110	24.560	0.16	0.16	1.34	79	2.00	1.09	79	1.10	91	0.054	100	100	25.5	-0.1	242	72	70	72	68	68	-0.029	1.98	0.011
151	24.271	24.724	0.16	0.16	1.34	79	2.00	1.08	79	1.10	91	0.056	98	98	25.5	0.0	242	72	70	72	68	68	-0.031	1.57	0.021
152	24.433	24.887	0.16	0.16	1.35	79	2.00	1.09	79	1.10	91	0.055	100	99	25.5	0.0	248	72	70	72	68	68	-0.030	2.71	0.003
153	24.595	25.052	0.16	0.16	1.35	79	1.99	1.09	79	1.10	91	0.054	100	101	25.4	-0.1	245	72	70	72	68	68	-0.031	1.75	0.013
154	24.756	25.216	0.16	0.16	1.34	79	2.00	1.09	79	1.10	92	0.054	100	100	25.4	0.0	251	72	70	72	68	68	-0.031	2.40	0.013
155	24.918	25.380	0.16	0.16	1.35	79	2.00	1.09	79	1.10	91	0.054	100	100	25.3	-0.1	250	72	70	72	68	68	-0.032	2.49	0.004
156	25.079	25.545	0.16	0.17	1.34	79	1.99	1.09	79	1.10	91	0.056	98	99	25.3	0.0	248	72	70	72	68	68	-0.031	2.14	0.006
157	25.241	25.708	0.16	0.16	1.34	79	2.00	1.08	79	1.10	91	0.056	99	98	25.3	0.0	250	72	70	72	68	68	-0.031	2.01	0.033
158	25.402	25.872	0.16	0.16	1.35	79	2.00	1.09	79	1.10	92	0.055	99	99	25.2	-0.1	250	72	70	72	68	68	-0.031	2.24	0.005
159	25.564	26.036	0.16	0.16	1.35	79	2.00	1.09	79	1.10	92	0.055	100	99	25.2	0.0	249	72	70	72	68	68	-0.031	1.75	0.018
160	25.725	26.200	0.16	0.16	1.35	79	1.99	1.10	79	1.10	92	0.055	99	99	25.2	0.0	252	72	70	72	68	68	-0.031	2.12	0.010
161	25.887	26.364	0.16	0.16	1.34	79	1.99	1.09	79	1.10	92	0.056	99	98	25.1	-0.1	252	72	70	72	68	68	-0.031	1.94	0.006
162	26.048	26.529	0.16	0.16	1.34	79	2.00	1.09	79	1.10	92	0.056	98	99	25.1	0.0	251	72	70	72	68	68	-0.030	2.09	0.015
163	26.210	26.693	0.16	0.16	1.34	79	2.00	1.08	79	1.10	92	0.054	101	100	25.0	-0.1	254	72	70	72	68	68	-0.032	2.08	0.019
164	26.371	26.856	0.16	0.16	1.34	79	2.00	1.09	79	1.10	92	0.055	99	99	25.0	0.0	255	72	70	72	68	68	-0.032	2.61	0.005
165	26.533	27.020	0.16	0.16	1.35	79	2.00	1.09	79	1.10	92	0.056	99	98	25.0	0.0	257	72	70	72	68	68	-0.032	2.60	0.006
166	26.694	27.184	0.16	0.16	1.35	79	2.00	1.09	79	1.10	92	0.055	99	99	24.9	-0.1	258	72	70	72	68	67	-0.032	2.73	0.011
167	26.856	27.348	0.16	0.16	1.35	79	1.99	1.09	79	1.10	93	0.055	100	99	24.9	0.0	259	72	70	72	68	68	-0.032	2.34	0.008
168	27.018	27.513	0.16	0.17	1.34	79	2.00	1.09	79	1.10	93	0.056	99	99	24.8	-0.1	259	72	69	72	68	67	-0.032	1.88	0.011
169	27.179	27.677	0.16	0.16	1.34	79	2.00	1.09	79	1.10	93	0.054	100	100	24.8	0.0	261	72	70	72	68	68	-0.032	2.49	0.005
170	27.341	27.841	0.16	0.16	1.34	79	1.99	1.09	79	1.10	93	0.055	100	99	24.7	-0.1	259	72	70	72	68	68	-0.032	1.93	0.011
171	27.502	28.005	0.16	0.16	1.34	79	2.00	1.09	79	1.10	93	0.054	100	100	24.7	0.0	264	72	70	72	68	67	-0.034	2.45	0.008
172	27.664	28.169	0.16	0.16	1.35	79	1.99	1.09	79	1.10	93	0.055	100	99	24.6	-0.1	267	72	70	72	68	67	-0.032	3.07	0.006
173	27.825	28.333	0.16	0.16	1.35	79	2.00	1.09	79	1.10	93	0.055	99	99	24.6	0.0	264	72	69	72	68	68	-0.033	2.10	0.009
174	27.987	28.497	0.16	0.16	1.35	79	2.00	1.09	79	1.10	93	0.055	100	99	24.6	0.0	263	72	69	72	69	68	-0.033	2.30	0.009
175	28.148	28.662	0.16	0.16	1.34	79	2.00	1.09	79	1.10	94	0.054	100	101	24.5	-0.1	264	72	69	72	69	68	-0.033	1.90	0.013
176	28.310	28.826	0.16	0.16	1.34	79	2.00	1.09	79	1.10	94	0.057	98	98	24.5	0.0	265	72	69	72	69	68	-0.033	2.29	0.006
177	28.471	28.989	0.16	0.16	1.34	79	2.00	1.09	79	1.10	93	0.056	98	98	24.4	-0.1	265	72	69	72	69	67	-0.031	2.63	0.004
178	28.633	29.154	0.16	0.16	1.34	79	2.01	1.09	79	1.10	94	0.056	99	99	24.4	0.0	264	72	69	72	69	67	-0.033	1.72	0.028
179	28.795	29.318	0.16	0.16	1.34	79	2.00	1.09	79	1.10	94	0.055	100	99	24.4	0.0	264	72	69	72	69	68	-0.033	2.20	0.010
180	28.956	29.482	0.16	0.16	1.34	79	2.00	1.09	79	1.10	94	0.055	99	99	24.3	-0.1	264	72	69	72	69	68	-0.033	2.08	0.013
181	29.118	29.647	0.16	0.16	1.34	79	2.01	1.09	79	1.10	95	0.056	99	99	24.3	0.0	270	72	69	72	69	68	-0.034	3.36	0.003
182	29.279	29.810	0.16	0.16	1.34	79	2.00	1.09	79	1.10	98	0.056	99	98	24.2	-0.1	282	72	69	73	69	68	-0.036	2.30	0.011
183	29.441	29.974	0.16	0.16	1.34	79	2.00	1.09	79	1.10	99	0.053	102	102	24.2	0.0	285	72	69	73	69	68	-0.035	2.81	0.005
184	29.602	30.138	0.16	0.16	1.34	79	2.01	1.09	79	1.10	100	0.054	101	101	24.1	-0.1	290	72	69	73	69	68	-0.037	1.99	0.028
185	29.764	30.302	0.16	0.16	1.35	79	2.00	1.09	79	1.10	99	0.055	100	100	24.0	-0.1	291	72	69	73	69	67	-0.036	3.71	0.003
186	29.925	30.466	0.16	0.16	1.35	79	1.99	1.09	79	1.10	97	0.056	99	99	24.0	0.0	283	72	69	73	69	68	-0.034	2.04	0.009
187	30.087	30.631	0.16	0.16	1.35	79	2.00	1.09	79	1.10	97	0.054	101	101	24.0	0.0	279	72	69	73	69	68	-0.034	2.23	0.027
188	30.248	30.795	0.16	0.16	1.34	79	1.99	1.09	79	1.10	96	0.055	99	100	24.0	0.0	272	72	69	73	69	68	-0.034	1.53	0.020
189	30.410	30.959	0.16	0.16	1.35	79	2.01	1.09	79	1.10	96	0.055	100	100	23.9	-0.1	270	73	69	73	69	68	-0.032	1.67	0.017
190	30.572	31.122	0.16	0.16	1.34	79	2.00	1.09	79	1.10	95	0.055	100	99	23.9	0.0	267	73	69	73	69	68	-0.032	1.59	0.018
191	30.733	31.286	0.16	0.16	1.35	79	1.99	1.09	79	1.10	94	0.055	99	99	23.9	0.0	263	73	69	73	69	67	-0.032	1.55	0.032
192	30.895	31.450	0.16	0.16	1.35	79	2.00	1.09	79	1.10	94	0.056	99	99	23.8	-0.1	260	73	69	73	69	68	-0.032	2.01	0.006
193	31.056	31.615	0.16	0.16	1.34	79	2.00	1.09	79	1.10	94	0.054	100	101	23.8	0.0	258	73	69	73	69	68	-0.031	1.90	0.015
194	31.218	31.779	0.16	0.16	1.34	79																			

Pellet Heater Test Data - ASTM E2779 / ASTM E2515

Run: 1

Manufacturer: Hearth & Home High Burn End Time: 60
 Model: CB 1200I-C Medium Burn End Time: 180
 Tracking No.: 2332 Total Sampling Time: 360 min
 Project No.: 0061PM077E Recording Interval: 1 min
 Test Date: 18-Dec-18
 Beginning Clock Time: 10:57 Background Sample Volume: 0 cubic feet
 Meter Box Y Factor: 0.986 (1) 0.985 (2) 0 (Amb)

Barometric Pressure: Begin Middle End Average
30.01 30.02 30.02 30.02 ^{"Hg}

PM Control Modules: 1335, 00336
 Dilution Tunnel MW(dry): 29.00 lb/lb-mole
 Dilution Tunnel MW(wet): 28.78 lb/lb-mole
 Dilution Tunnel H₂O: 2.00 percent
 Dilution Tunnel Static: -0.220 ^{"H₂O}
 Tunnel Area: 0.1963 ^{ft²}
 Pitot Tube Cp: 0.99

Avg. Tunnel Velocity: 14.12 ft/sec.
 Initial Tunnel Flow: 150.7 scfm
 Average Tunnel Flow: 154.2 scfm
 Post-Test Leak Check (1): 0.000 cfm @ 10 in. Hg
 Post-Test Leak Check (2): 0.000 cfm @ 7 in. Hg
 Fuel Moisture (%): 6.689 Dry Basis 6.270 Wet Basis

Velocity Traverse Data									
	Pt. 1	Pt. 2	Pt. 3	Pt. 4	Pt. 5	Pt. 6	Pt. 7	Pt. 8	Center
Initial dP	0.038	0.050	0.046	0.036	0.036	0.048	0.050	0.036	0.054
Temp:	116	117	117	117	117	117	117	117	117
V _{strav} 14.23 ft/sec			V _{scent} 16.08 ft/sec			F _p 0.885			^{"H₂O} ^{"F}

Elapsed Time (min)	Particulate Sampling Data												Fuel Weight (lb)		Temperature Data (°F)						Stack Gas Data				
	Gas Meter 1 (ft ³)	Gas Meter 2 (ft ³)	Sample Rate 1 (cfm)	Sample Rate 2 (cfm)	Orifice dH 1 (H ₂ O)	Meter Temp 1 (°F)	Meter Vacuum 1 (H _g)	Orifice dH 2 (H ₂ O)	Meter Temp 2 (°F)	Meter Vacuum 2 (H _g)	Dilution Tunnel (°F)	Tunnel Center dP	Pro. Rate 1	Pro. Rate 2	Scale Reading	Weight Change	Stack	Filter 1	Dryer 1	Filter 2	Dryer 2	Ambient	Draft (H ₂ O)	CO ₂ (%)	CO (%)
196	31.541	32.107	0.16	0.16	1.34	79	1.99	1.09	79	1.10	93	0.056	99	98	23.7	0.0	253	72	69	73	69	67	-0.031	1.84	0.013
197	31.702	32.271	0.16	0.16	1.34	79	2.00	1.09	79	1.10	93	0.055	99	99	23.7	0.0	253	72	69	73	69	67	-0.030	1.64	0.020
198	31.864	32.435	0.16	0.16	1.34	79	2.00	1.09	79	1.10	92	0.056	99	98	23.6	-0.1	253	72	69	73	69	67	-0.032	1.94	0.013
199	32.025	32.599	0.16	0.16	1.34	79	1.99	1.09	79	1.10	92	0.054	100	100	23.6	0.0	253	72	69	73	69	67	-0.031	2.45	0.007
200	32.187	32.764	0.16	0.17	1.35	79	2.00	1.08	79	1.10	92	0.055	100	100	23.6	0.0	254	72	69	73	69	67	-0.031	2.40	0.006
201	32.348	32.927	0.16	0.16	1.35	79	1.99	1.09	79	1.10	92	0.055	99	99	23.5	-0.1	254	72	69	73	69	67	-0.031	1.78	0.016
202	32.510	33.091	0.16	0.16	1.35	79	2.00	1.09	79	1.10	92	0.055	100	99	23.5	0.0	251	72	69	73	69	67	-0.031	1.97	0.015
203	32.672	33.256	0.16	0.16	1.35	79	2.00	1.09	79	1.10	92	0.055	100	100	23.5	0.0	249	72	69	73	69	67	-0.031	1.75	0.022
204	32.833	33.419	0.16	0.16	1.35	79	2.00	1.09	79	1.10	92	0.054	100	100	23.4	-0.1	250	72	69	72	69	67	-0.030	1.93	0.017
205	32.995	33.583	0.16	0.16	1.35	79	2.00	1.09	79	1.10	92	0.055	100	99	23.4	0.0	248	72	69	72	69	67	-0.031	2.11	0.011
206	33.156	33.748	0.16	0.16	1.35	79	2.00	1.09	79	1.10	91	0.056	98	99	23.4	0.0	245	72	69	72	69	67	-0.030	1.58	0.020
207	33.318	33.912	0.16	0.16	1.34	79	2.01	1.09	79	1.10	92	0.055	100	99	23.3	-0.1	248	72	69	72	69	68	-0.030	1.76	0.014
208	33.479	34.076	0.16	0.16	1.35	79	2.00	1.08	79	1.10	92	0.055	99	99	23.3	0.0	252	72	69	72	69	67	-0.032	2.26	0.006
209	33.641	34.240	0.16	0.16	1.34	79	2.00	1.09	79	1.10	92	0.055	100	99	23.3	0.0	251	72	69	72	69	67	-0.031	2.02	0.008
210	33.803	34.404	0.16	0.16	1.35	79	2.00	1.09	79	1.10	91	0.055	100	99	23.3	0.0	247	72	69	72	69	68	-0.030	1.98	0.013
211	33.964	34.568	0.16	0.16	1.35	79	2.00	1.09	79	1.10	91	0.056	98	98	23.2	-0.1	245	72	69	72	69	67	-0.030	1.90	0.022
212	34.126	34.733	0.16	0.16	1.35	79	2.00	1.10	79	1.10	91	0.056	99	99	23.2	0.0	250	72	69	72	69	67	-0.031	1.69	0.025
213	34.287	34.897	0.16	0.16	1.34	79	2.01	1.09	79	1.10	92	0.054	100	100	23.1	-0.1	253	72	69	72	69	68	-0.030	2.03	0.007
214	34.449	35.061	0.16	0.16	1.35	79	2.01	1.09	79	1.10	92	0.056	99	98	23.1	0.0	252	72	69	72	69	68	-0.031	2.09	0.011
215	34.610	35.225	0.16	0.16	1.34	79	2.00	1.08	79	1.10	92	0.055	99	99	23.1	0.0	252	72	69	72	69	68	-0.030	2.47	0.007
216	34.772	35.389	0.16	0.16	1.35	79	2.00	1.09	79	1.10	92	0.054	101	100	23.0	-0.1	250	72	69	72	69	68	-0.029	1.97	0.013
217	34.934	35.553	0.16	0.16	1.35	79	1.99	1.09	79	1.10	92	0.055	100	99	23.0	0.0	245	72	69	72	69	68	-0.029	1.37	0.027
218	35.095	35.717	0.16	0.16	1.35	79	2.00	1.09	79	1.10	92	0.054	100	100	23.0	0.0	242	72	69	72	69	68	-0.028	1.38	0.028
219	35.257	35.882	0.16	0.16	1.35	79	2.00	1.09	79	1.10	92	0.055	100	100	23.0	0.0	240	72	69	72	69	68	-0.028	1.29	0.027
220	35.418	36.046	0.16	0.16	1.35	79	2.01	1.09	79	1.10	92	0.055	99	99	22.9	-0.1	241	72	69	72	69	68	-0.029	1.98	0.014
221	35.580	36.210	0.16	0.16	1.34	79	2.00	1.08	79	1.10	92	0.054	101	100	22.9	0.0	237	72	69	72	69	68	-0.028	1.73	0.022
222	35.742	36.374	0.16	0.16	1.35	79	2.00	1.09	79	1.10	92	0.055	100	99	22.9	0.0	238	72	69	72	69	68	-0.029	1.73	0.024
223	35.903	36.538	0.16	0.16	1.35	79	2.00	1.09	79	1.10	92	0.055	99	99	22.9	0.0	241	72	69	72	69	68	-0.028	2.34	0.013
224	36.065	36.702	0.16	0.16	1.35	79	2.01	1.09	79	1.10	93	0.056	99	98	22.8	-0.1	238	72	69	72	68	68	-0.027	1.62	0.021
225	36.226	36.867	0.16	0.16	1.34	79	2.00	1.09	79	1.10	93	0.055	99	100	22.8	0.0	238	72	69	72	68	68	-0.028	1.40	0.028
226	36.388	37.031	0.16	0.16	1.35	79	2.01	1.09	79	1.10	93	0.056	99	98	22.7	-0.1	239	72	69	72	68	68	-0.029	2.39	0.008
227	36.549	37.195	0.16	0.16	1.35	79	2.00	1.08	79	1.10	93	0.055	99	99	22.7	0.0	239	72	69	72	68	68	-0.027	2.10	0.012
228	36.711	37.359	0.16	0.16	1.34	79	2.01	1.09	79	1.10	93	0.056	99	98	22.7	0.0	242	72	69	72	68	68	-0.028	1.79	0.016
229	36.872	37.523	0.16	0.16	1.34	79	2.01	1.09	79	1.10	93	0.055	99	99	22.6	-0.1	248	72	69	73	68	68	-0.029	2.47	0.009
230	37.034	37.687	0.16	0.16	1.35	79	2.00	1.09	79	1.10	94	0.055	100	99	22.6	0.0	247	72	69	73	68	68	-0.030	2.45	0.005
231	37.195	37.851	0.16	0.16	1.34	79	2.00	1.09	79	1.10	93	0.054	100	100	22.6	0.0	242	73	69	73	68	68	-0.028	1.47	0.043
232	37.357	38.016	0.16	0.16	1.34	79	2.00	1.09	79	1.10	94	0.056	99	99	22.5	-0.1	241	73	69	73	68	69	-0.027	1.44	0.018
233	37.518	38.180	0.16	0.16	1.34	79	2.00	1.08	79	1.10	94	0.056	98	99	22.5	0.0	243	73	69	73	68	69	-0.028	1.66	0.028
234	37.680	38.344	0.16	0.16	1.34	79	2.00	1.09	80	1.10	94	0.054	101	100	22.5	0.0	242	73	69	73	69	68	-0.028	1.92	0.012
235	37.841	38.507	0.16	0.16	1.35	79	2.00	1.09	80	1.10	94	0.055	99	99	22.5	0.0	238	73	69	73	69	69	-0.028	1.92	0.009
236	38.003	38.671	0.16	0.16	1.34	79	2.00	1.09	80	1.10	94	0.056	99	98	22.4	-0.1	234	73	69	73	68	69	-0.026	1.01	0.060
237	38.164	38.835	0.16	0.16	1.35	79	2.01	1.09	80	1.10	94	0.055	99	99	22.4	0.0	236	73	69	73	69	69	-0.027	1.55	0.015
238	38.326	39.000	0.16	0.16	1.35	79	2.01	1.09	80	1.10	94	0.055	100	100	22.4	0.0	236	73	69	73	69	69	-0.026	2.39	0.006
239	38.487	39.164	0.16	0.16	1.33	79	2.01	1.09	80	1.10	94	0.055	99	99	22.4	0.0	236	73	69	73	68	69	-0.027	1.77	0.022
240	38.649	39.328	0.16	0.16	1.34	79	2.01	1.08	80	1.10	94	0.056	99	98	22.3	-0.1	237	73	69	73	69	69	-0.028	1.73	0.016
241	38.810	39.492	0.16	0.16	1.34	79	2.01	1.09	80	1.10	94	0.055	99	99	22.3	0.0	241	73	69	73	69	69	-0.027	2.65	0.011
242	38.971	39.655	0.16	0.16	1.34	79	2.01	1.09	80	1.10	94	0.054	100	100	22.3	0.0	240	73	69	73	69	69	-0.028	1.81	0.020
243																									

Pellet Heater Test Data - ASTM E2779 / ASTM E2515

Run: 1

Manufacturer: Hearth & Home High Burn End Time: 60
 Model: CB 12001-C Medium Burn End Time: 180
 Tracking No.: 2332 Total Sampling Time: 360 min
 Project No.: 0061PM077E Recording Interval: 1 min
 Test Date: 18-Dec-18
 Beginning Clock Time: 10:57 Background Sample Volume: 0 cubic feet
 Meter Box Y Factor: 0.986 (1) 0.985 (2) 0 (Amb)
 Barometric Pressure: Begin Middle End Average
 30.01 30.02 30.02 30.02 ¹Hg

PM Control Modules: 1335, 00336
 Dilution Tunnel MW(dry): 29.00 lb/lb-mole
 Dilution Tunnel MW(wet): 28.78 lb/lb-mole
 Dilution Tunnel H2O: 2.00 percent
 Dilution Tunnel Static: -0.220 ¹H₂O
 Tunnel Area: 0.1963 ft²
 Pitot Tube Cp: 0.99

Avg. Tunnel Velocity: 14.12 ft/sec.
 Initial Tunnel Flow: 150.7 scfm
 Average Tunnel Flow: 154.2 scfm
 Post-Test Leak Check (1): 0.000 cfm @ 10 in. Hg
 Post-Test Leak Check (2): 0.000 cfm @ 7 in. Hg
 Fuel Moisture (%): 6.689 Dry Basis 6.270 Wet Basis

Velocity Traverse Data									
	Pt.1	Pt.2	Pt.3	Pt.4	Pt.5	Pt.6	Pt.7	Pt.8	Center
Initial dP	0.038	0.050	0.046	0.036	0.036	0.048	0.050	0.036	0.054
Temp:	116	117	117	117	117	117	117	117	117
V _{strav}	14.23			ft/sec			V _{scent}		
	16.08			ft/sec			F _p		
	0.885								

Elapsed Time (min)	Particulate Sampling Data												Fuel Weight (lb)		Temperature Data (°F)						Stack Gas Data				
	Gas Meter 1 (ft ³)	Gas Meter 2 (ft ³)	Sample Rate 1 (cfm)	Sample Rate 2 (cfm)	Orifice dH 1 (°H ₂ O)	Meter Temp 1 (°F)	Meter Vacuum 1 (°Hg)	Orifice dH 2 (°H ₂ O)	Meter Temp 2 (°F)	Meter Vacuum 2 (°Hg)	Dilution Tunnel (°F)	Tunnel Center dP	Pro. Rate 1	Pro. Rate 2	Scale Reading	Weight Change	Stack	Filter 1	Dryer 1	Filter 2	Dryer 2	Ambient	Draft (°H ₂ O)	CO ₂ (%)	CO (%)
245	39.456	40.149	0.16	0.16	1.34	79	2.01	1.09	80	1.10	94	0.056	99	99	22.1	-0.1	242	73	69	73	69	69	-0.028	2.04	0.011
246	39.617	40.312	0.16	0.16	1.34	79	2.00	1.08	80	1.10	94	0.056	98	98	22.1	0.0	242	73	69	73	69	69	-0.028	1.94	0.025
247	39.778	40.476	0.16	0.16	1.34	79	2.00	1.09	80	1.10	95	0.056	98	98	22.0	-0.1	244	73	69	73	69	69	-0.029	1.93	0.019
248	39.940	40.640	0.16	0.16	1.33	79	2.00	1.09	80	1.10	95	0.057	98	98	22.0	0.0	243	73	69	73	69	69	-0.027	2.05	0.012
249	40.101	40.804	0.16	0.16	1.33	79	2.01	1.09	80	1.10	95	0.055	99	99	22.0	0.0	243	73	69	73	69	69	-0.027	2.02	0.009
250	40.263	40.968	0.16	0.16	1.33	79	2.01	1.09	80	1.10	95	0.056	99	98	21.9	-0.1	243	73	69	73	69	69	-0.027	1.93	0.014
251	40.424	41.133	0.16	0.16	1.34	79	2.01	1.09	80	1.10	95	0.056	98	99	21.9	0.0	246	73	69	73	69	69	-0.029	2.12	0.010
252	40.585	41.296	0.16	0.16	1.34	79	2.01	1.08	80	1.10	95	0.056	98	98	21.8	-0.1	247	73	69	73	69	69	-0.028	2.20	0.012
253	40.747	41.460	0.16	0.16	1.34	79	2.01	1.09	80	1.10	95	0.055	100	99	21.8	0.0	244	73	69	73	69	70	-0.027	2.25	0.011
254	40.908	41.624	0.16	0.16	1.33	79	2.00	1.09	80	1.10	95	0.056	98	98	21.8	0.0	243	73	69	73	69	69	-0.027	2.15	0.010
255	41.069	41.788	0.16	0.16	1.34	79	2.01	1.09	80	1.10	95	0.056	98	98	21.8	0.0	238	74	69	74	69	69	-0.028	1.33	0.050
256	41.231	41.952	0.16	0.16	1.34	79	2.00	1.09	80	1.10	95	0.055	100	99	21.7	-0.1	239	74	69	74	69	69	-0.026	1.80	0.027
257	41.392	42.117	0.16	0.16	1.34	79	2.01	1.09	80	1.10	95	0.055	99	100	21.7	0.0	241	74	69	73	69	68	-0.027	2.05	0.016
258	41.553	42.281	0.16	0.16	1.34	80	2.00	1.09	80	1.10	95	0.055	99	99	21.7	0.0	242	74	69	73	69	68	-0.028	1.70	0.017
259	41.715	42.445	0.16	0.16	1.33	80	2.00	1.08	80	1.10	95	0.055	100	99	21.6	-0.1	240	74	69	73	69	68	-0.028	1.57	0.017
260	41.876	42.608	0.16	0.16	1.34	80	2.01	1.09	80	1.10	95	0.055	99	99	21.6	0.0	240	74	69	73	69	68	-0.027	1.98	0.017
261	42.038	42.772	0.16	0.16	1.34	80	2.01	1.09	80	1.10	95	0.056	99	98	21.6	0.0	237	74	69	73	69	68	-0.027	1.61	0.022
262	42.199	42.936	0.16	0.16	1.34	80	2.01	1.09	80	1.10	95	0.056	98	98	21.6	0.0	234	73	69	73	69	69	-0.027	1.41	0.026
263	42.361	43.101	0.16	0.16	1.34	80	2.01	1.09	80	1.10	95	0.056	99	99	21.5	-0.1	237	73	69	73	69	68	-0.027	1.72	0.019
264	42.522	43.265	0.16	0.16	1.34	80	2.01	1.09	80	1.10	95	0.055	99	99	21.5	0.0	235	73	69	73	69	69	-0.026	2.35	0.011
265	42.683	43.429	0.16	0.16	1.33	80	2.01	1.09	80	1.10	95	0.054	100	100	21.4	-0.1	238	73	69	73	69	68	-0.028	1.49	0.037
266	42.845	43.593	0.16	0.16	1.34	80	2.01	1.09	80	1.10	95	0.056	99	98	21.4	0.0	239	73	69	73	69	68	-0.028	2.34	0.010
267	43.006	43.757	0.16	0.16	1.34	80	2.01	1.09	80	1.10	95	0.056	98	98	21.4	0.0	238	73	69	73	69	68	-0.027	2.12	0.011
268	43.168	43.921	0.16	0.16	1.34	80	2.01	1.09	80	1.10	95	0.056	99	98	21.3	-0.1	239	73	69	73	69	68	-0.028	2.01	0.010
269	43.329	44.085	0.16	0.16	1.34	80	2.00	1.09	80	1.10	95	0.056	98	98	21.3	0.0	239	73	69	73	69	68	-0.027	1.79	0.012
270	43.491	44.250	0.16	0.16	1.33	80	2.00	1.08	80	1.10	95	0.056	99	99	21.3	0.0	238	73	69	73	69	68	-0.028	1.78	0.017
271	43.652	44.414	0.16	0.16	1.33	80	2.00	1.09	80	1.10	95	0.055	99	99	21.3	0.0	236	73	69	73	69	68	-0.026	1.77	0.014
272	43.814	44.578	0.16	0.16	1.34	80	2.01	1.09	80	1.10	95	0.056	99	98	21.2	-0.1	234	73	69	73	69	68	-0.026	1.65	0.027
273	43.976	44.742	0.16	0.16	1.34	80	2.01	1.09	80	1.10	95	0.055	100	99	21.2	0.0	233	73	69	73	69	68	-0.026	1.41	0.032
274	44.137	44.906	0.16	0.16	1.34	80	2.00	1.09	80	1.10	95	0.054	100	100	21.2	0.0	233	73	69	73	69	68	-0.026	1.63	0.020
275	44.298	45.070	0.16	0.16	1.34	80	2.00	1.09	80	1.10	95	0.055	99	99	21.1	-0.1	235	73	69	73	69	68	-0.027	1.92	0.014
276	44.460	45.235	0.16	0.16	1.34	80	2.00	1.09	80	1.10	95	0.056	99	99	21.1	0.0	235	73	69	73	69	68	-0.026	2.20	0.014
277	44.621	45.399	0.16	0.16	1.34	80	2.00	1.09	80	1.10	95	0.055	99	99	21.1	0.0	235	73	69	73	69	68	-0.027	1.96	0.021
278	44.783	45.563	0.16	0.16	1.34	80	2.01	1.09	80	1.10	95	0.056	99	98	21.0	-0.1	237	73	69	73	69	68	-0.027	1.83	0.028
279	44.944	45.726	0.16	0.16	1.33	80	2.01	1.09	80	1.10	95	0.056	98	98	21.0	0.0	234	73	69	73	69	68	-0.026	1.77	0.018
280	45.106	45.890	0.16	0.16	1.34	80	2.00	1.09	80	1.10	95	0.055	100	99	21.0	0.0	234	73	69	73	69	68	-0.026	1.69	0.021
281	45.267	46.055	0.16	0.16	1.34	80	2.00	1.09	80	1.10	95	0.057	97	98	20.9	-0.1	237	73	69	73	69	68	-0.027	1.73	0.016
282	45.429	46.219	0.16	0.16	1.34	80	2.01	1.09	80	1.10	95	0.054	101	100	20.9	0.0	237	73	69	73	69	68	-0.027	2.04	0.014
283	45.591	46.384	0.16	0.16	1.34	80	2.01	1.09	80	1.10	95	0.056	99	99	20.9	0.0	238	73	69	73	69	68	-0.027	1.83	0.015
284	45.752	46.548	0.16	0.16	1.34	80	2.01	1.09	80	1.10	95	0.056	98	98	20.8	-0.1	235	73	69	73	69	68	-0.026	1.87	0.018
285	45.914	46.711	0.16	0.16	1.34	80	2.01	1.09	80	1.10	95	0.054	101	100	20.8	0.0	238	73	69	73	69	68	-0.028	2.10	0.018
286	46.075	46.875	0.16	0.16	1.34	80	2.01	1.09	80	1.10	95	0.055	99	99	20.8	0.0	238	73	69	73	69	68	-0.027	2.06	0.007
287	46.237	47.040	0.16	0.16	1.34	80	2.01	1.09	80	1.10	95	0.055	100	100	20.7	-0.1	236	73	69	73	69	68	-0.027	1.91	0.020
288	46.398	47.203	0.16	0.16	1.34	80	2.01	1.09	80	1.10	95	0.056	98	98	20.7	0.0	240	73	69	73	69	68	-0.027	2.04	0.025
289	46.560	47.368	0.16	0.16	1.34	80	2.00	1.08	80	1.10	96	0.055	100	100	20.7	0.0	240	73	69	73	69	67	-0.027	2.00	0.018
290	46.721	47.532	0.16	0.16	1.33	80	2.00	1.09	80	1.10	96	0.055	99	99	20.6	-0.1	239	73	69	73	69	67	-0.026	1.76	0.030
291	46.883	47.696	0.16	0.16	1.34	80	2.00	1.09	80	1.10	96	0.056	99	99	20.6	0.0	235	73	69	73	69	68	-0.025	1.37	0.027
292	47.044	47.860	0.16	0.16	1.34																				

Pellet Heater Test Data - ASTM E2779 / ASTM E2515

Run: 1

Manufacturer: Hearth & Home High Burn End Time: 60
 Model: CB 1200I-C Medium Burn End Time: 180
 Tracking No.: 2332 Total Sampling Time: 360 min
 Project No.: 0061PM077E Recording Interval: 1 min
 Test Date: 18-Dec-18
 Beginning Clock Time: 10:57 Background Sample Volume: 0 cubic feet

Meter Box Y Factor: 0.986 (1) 0.985 (2) 0 (Amb)

Barometric Pressure: 30.01 30.02 30.02 30.02 "Hg
 (Begin Middle End Average)

PM Control Modules: 0335, 00336
 Dilution Tunnel MW(dry): 29.00 lb/lb-mole
 Dilution Tunnel MW(wet): 28.78 lb/lb-mole
 Dilution Tunnel H₂O: 2.00 percent
 Dilution Tunnel Static: -0.220 "H₂O
 Tunnel Area: 0.1963 ft²
 Pitot Tube Cp: 0.99

Avg. Tunnel Velocity: 14.12 ft/sec.
 Initial Tunnel Flow: 150.7 scfm
 Average Tunnel Flow: 154.2 scfm
 Post-Test Leak Check (1): 0.000 cfm @ 10 in. Hg
 Post-Test Leak Check (2): 0.000 cfm @ 7 in. Hg
 Fuel Moisture (%): 6.689 Dry Basis 6.270 Wet Basis

Velocity Traverse Data									
	Pt.1	Pt.2	Pt.3	Pt.4	Pt.5	Pt.6	Pt.7	Pt.8	Center
Initial dP	0.038	0.050	0.046	0.036	0.036	0.048	0.050	0.036	0.054
Temp:	116	117	117	117	117	117	117	117	117
	V _{strav} 14.23 ft/sec			V _{scnt} 16.08 ft/sec		F _p 0.885			

Elapsed Time (min)	Particulate Sampling Data										Fuel Weight (lb)				Temperature Data (°F)							Stack Gas Data			
	Gas Meter 1 (ft³)	Gas Meter 2 (ft³)	Sample Rate 1 (cfm)	Sample Rate 2 (cfm)	Orifice dH 1 ("H ₂ O)	Meter Temp 1 (°F)	Meter Vacuum 1 ("Hg)	Orifice dH 2 ("H ₂ O)	Meter Temp 2 (°F)	Meter Vacuum 2 ("Hg)	Dilution Tunnel (°F)	Tunnel Center dP	Pro. Rate 1	Pro. Rate 2	Scale Reading	Weight Change	Stack	Filter 1	Dryer 1	Filter 2	Dryer 2	Ambient	Draft ("H ₂ O)	CO ₂ (%)	CO (%)
294	47.367	48.189	0.16	0.16	1.34	80	2.01	1.09	80	1.10	95	0.054	100	101	20.5	0.0	234	73	69	73	69	67	-0.026	2.06	0.008
295	47.529	48.353	0.16	0.16	1.34	80	2.00	1.09	80	1.10	95	0.055	100	99	20.5	0.0	228	73	69	73	69	68	-0.025	1.49	0.021
296	47.690	48.518	0.16	0.16	1.34	80	2.01	1.09	80	1.10	95	0.056	98	99	20.5	0.0	229	73	69	73	69	67	-0.025	1.62	0.031
297	47.852	48.681	0.16	0.16	1.33	80	2.00	1.08	80	1.10	95	0.055	100	99	20.4	-0.1	224	73	69	73	69	67	-0.024	1.00	0.046
298	48.014	48.845	0.16	0.16	1.33	80	2.00	1.09	80	1.10	95	0.055	100	99	20.4	0.0	225	73	69	73	69	68	-0.026	0.89	0.052
299	48.175	49.009	0.16	0.16	1.34	80	2.01	1.09	80	1.10	95	0.055	99	99	20.4	0.0	227	73	69	73	69	67	-0.026	1.85	0.010
300	48.336	49.173	0.16	0.16	1.34	80	2.00	1.09	80	1.10	95	0.056	98	98	20.3	-0.1	231	73	69	73	69	68	-0.026	2.51	0.015
301	48.498	49.337	0.16	0.16	1.34	80	2.01	1.09	80	1.10	95	0.054	101	100	20.3	0.0	236	73	69	73	69	67	-0.028	2.21	0.007
302	48.659	49.503	0.16	0.17	1.34	80	2.00	1.09	80	1.10	95	0.056	98	100	20.3	0.0	235	73	69	73	69	67	-0.026	2.25	0.016
303	48.821	49.666	0.16	0.16	1.33	80	2.01	1.09	80	1.10	95	0.056	99	98	20.2	-0.1	231	73	69	73	69	68	-0.026	1.38	0.049
304	48.982	49.830	0.16	0.16	1.34	80	2.01	1.09	80	1.10	95	0.055	99	99	20.2	0.0	231	73	69	73	69	68	-0.026	1.74	0.025
305	49.144	49.994	0.16	0.16	1.34	80	2.01	1.09	80	1.10	95	0.055	100	99	20.2	0.0	233	73	69	73	69	68	-0.026	1.90	0.016
306	49.305	50.158	0.16	0.16	1.34	80	2.01	1.09	80	1.10	95	0.055	99	99	20.1	-0.1	233	73	69	73	69	68	-0.026	2.16	0.007
307	49.467	50.322	0.16	0.16	1.34	80	2.01	1.09	80	1.10	95	0.055	100	99	20.1	0.0	234	73	69	73	69	68	-0.027	1.76	0.019
308	49.629	50.487	0.16	0.16	1.34	79	2.01	1.09	80	1.10	95	0.056	99	99	20.1	0.0	234	73	69	73	69	68	-0.027	1.95	0.018
309	49.790	50.651	0.16	0.16	1.34	79	2.01	1.09	80	1.10	95	0.056	98	98	20.0	-0.1	233	73	69	73	69	68	-0.026	1.70	0.028
310	49.952	50.815	0.16	0.16	1.34	79	2.01	1.09	80	1.10	95	0.056	99	98	20.0	0.0	231	73	69	73	69	67	-0.026	1.65	0.015
311	50.114	50.979	0.16	0.16	1.34	80	2.01	1.09	80	1.10	95	0.056	99	98	20.0	0.0	229	73	68	73	69	68	-0.026	1.67	0.018
312	50.275	51.143	0.16	0.16	1.34	80	2.02	1.09	80	1.10	95	0.057	97	98	20.0	0.0	228	73	69	73	69	68	-0.026	1.76	0.015
313	50.437	51.307	0.16	0.16	1.34	80	2.01	1.09	80	1.10	95	0.055	100	99	19.9	-0.1	231	73	69	73	69	68	-0.026	1.80	0.029
314	50.598	51.472	0.16	0.16	1.34	80	2.02	1.10	80	1.10	95	0.056	98	99	19.9	0.0	231	73	68	73	69	68	-0.026	1.48	0.027
315	50.760	51.637	0.16	0.16	1.34	80	2.01	1.09	80	1.10	95	0.055	100	100	19.9	0.0	235	73	68	73	69	67	-0.026	2.14	0.011
316	50.921	51.800	0.16	0.16	1.34	80	2.01	1.09	80	1.10	95	0.054	100	100	19.8	-0.1	233	73	68	73	69	68	-0.026	1.80	0.020
317	51.083	51.965	0.16	0.17	1.34	80	2.00	1.09	80	1.10	95	0.054	101	101	19.8	0.0	227	73	68	73	69	68	-0.025	1.59	0.020
318	51.245	52.128	0.16	0.16	1.34	79	2.01	1.09	80	1.10	95	0.055	100	99	19.8	0.0	230	73	68	73	69	68	-0.025	1.46	0.026
319	51.406	52.292	0.16	0.16	1.34	80	2.00	1.09	80	1.10	95	0.053	101	101	19.8	0.0	229	73	68	73	69	67	-0.025	1.90	0.012
320	51.568	52.456	0.16	0.16	1.34	80	2.01	1.09	80	1.10	95	0.055	100	99	19.7	-0.1	228	73	68	73	69	68	-0.025	1.29	0.044
321	51.729	52.621	0.16	0.16	1.34	80	2.01	1.08	80	1.10	95	0.055	99	100	19.7	0.0	230	73	68	73	69	68	-0.026	1.63	0.023
322	51.891	52.785	0.16	0.16	1.33	79	2.01	1.09	80	1.10	94	0.055	100	99	19.6	-0.1	233	73	68	73	69	68	-0.027	2.30	0.009
323	52.052	52.949	0.16	0.16	1.34	79	2.01	1.09	80	1.10	95	0.055	99	99	19.6	0.0	234	73	68	73	69	68	-0.026	2.21	0.012
324	52.214	53.113	0.16	0.16	1.34	79	2.01	1.09	80	1.10	95	0.055	100	99	19.6	0.0	233	73	68	73	69	68	-0.025	1.80	0.023
325	52.375	53.277	0.16	0.16	1.34	79	2.01	1.09	80	1.10	95	0.056	98	98	19.5	-0.1	238	73	68	73	69	68	-0.028	2.03	0.024
326	52.537	53.441	0.16	0.16	1.34	79	2.01	1.09	80	1.10	95	0.055	100	99	19.5	0.0	240	73	68	73	69	68	-0.028	2.28	0.012
327	52.698	53.605	0.16	0.16	1.34	79	2.02	1.09	80	1.10	95	0.055	99	99	19.4	-0.1	238	73	68	73	69	68	-0.028	2.12	0.015
328	52.860	53.770	0.16	0.17	1.33	79	2.02	1.09	80	1.10	96	0.054	101	101	19.4	0.0	244	73	68	73	69	67	-0.029	2.54	0.008
329	53.021	53.934	0.16	0.16	1.34	79	2.02	1.09	80	1.10	96	0.055	99	99	19.3	-0.1	246	73	68	73	69	67	-0.028	2.64	0.005
330	53.182	54.097	0.16	0.16	1.34	79	2.01	1.09	80	1.10	96	0.056	99	98	19.3	0.0	246	73	68	73	69	68	-0.028	2.23	0.014
331	53.344	54.262	0.16	0.16	1.34	79	2.01	1.09	80	1.10	96	0.055	100	100	19.3	0.0	246	73	68	73	69	68	-0.028	1.77	0.022
332	53.505	54.426	0.16	0.16	1.34	80	2.02	1.09	80	1.10	96	0.056	98	99	19.2	-0.1	245	73	68	73	69	68	-0.028	2.01	0.013
333	53.667	54.590	0.16	0.16	1.34	79	2.01	1.09	80	1.10	96	0.055	100	99	19.2	0.0	242	73	68	73	69	68	-0.027	1.98	0.008
334	53.828	54.755	0.16	0.16	1.34	79	2.01	1.09	80	1.10	96	0.054	100	101	19.2	0.0	240	73	68	73	69	68	-0.027	1.59	0.025
335	53.990	54.919	0.16	0.16	1.34	79	2.01	1.09	80	1.10	96	0.056	99	99	19.1	-0.1	242	73	68	73	69	68	-0.028	2.14	0.015
336	54.151	55.082	0.16	0.16	1.33	79	2.01	1.08	80	1.10	96	0.056	99	98	19.1	0.0	244	73	68	73	69	68	-0.028	2.05	0.016
337	54.313	55.246	0.16	0.16	1.33	79	2.01	1.09	80	1.10	96	0.055	100	99	19.1	0.0	241	73	68	73	69	67	-0.027	1.69	0.015
338	54.474	55.410	0.16	0.16	1.33	79	2.01	1.09	80	1.10	96	0.055	99	99	19.1	0.0	241	73	68	73	69	67	-0.028	1.57	0.023
339	54.636	55.574	0.16	0.16	1.34	79	2.01	1.09	80	1.10	96	0.056	99	99	19.0	-0.1	242	73	68	73	69	68	-0.028	2.16	0.010
340	54.797	55.739	0.16	0.16	1.34	79	2.01	1.09	80	1.10	96	0.055	99	100	19.0	0.0	241	73	68	73	69	68	-0.026	2.21	0.009
341	54.958																								

Pellet Heater Test Data - ASTM E2779 / ASTM E2515

Run: 1

Manufacturer: Hearth & Home High Burn End Time: 60
 Model: CB 1200I-C Medium Burn End Time: 180
 Tracking No.: 2332 Total Sampling Time: 360 min
 Project No.: 0061PM077E Recording Interval: 1 min
 Test Date: 18-Dec-18
 Beginning Clock Time: 10:57 Background Sample Volume: 0 cubic feet

Meter Box Y Factor: 0.986 (1) 0.985 (2) 0 (Amb)

Barometric Pressure: Begin Middle End Average
30.01 30.02 30.02 30.02 "Hg

PM Control Modules: 0335, 00336
 Dilution Tunnel MW(dry): 29.00 lb/lb-mole
 Dilution Tunnel MW(wet): 28.78 lb/lb-mole
 Dilution Tunnel H2O: 2.00 percent
 Dilution Tunnel Static: -0.220 "H₂O
 Tunnel Area: 0.1963 ft²
 Pitot Tube Cp: 0.99

Avg. Tunnel Velocity: 14.12 ft/sec.
 Initial Tunnel Flow: 150.7 scfm
 Average Tunnel Flow: 154.2 scfm
 Post-Test Leak Check (1): 0.000 cfm @ 10 in. Hg
 Post-Test Leak Check (2): 0.000 cfm @ 7 in. Hg
 Fuel Moisture (%): 6.689 Dry Basis 6.270 Wet Basis

Velocity Traverse Data									
	Pt.1	Pt.2	Pt.3	Pt.4	Pt.5	Pt.6	Pt.7	Pt.8	Center
Initial dP	0.038	0.050	0.046	0.036	0.036	0.048	0.050	0.036	0.054
Temp:	116	117	117	117	117	117	117	117	117
	V _{strav} 14.23 ft/sec			V _{scent} 16.08 ft/sec		F _p 0.885			

Elapsed Time (min)	Particulate Sampling Data												Fuel Weight (lb)		Temperature Data (°F)						Stack Gas Data				
	Gas Meter 1 (ft ³)	Gas Meter 2 (ft ³)	Sample Rate 1 (cfm)	Sample Rate 2 (cfm)	Orifice dH 1 ("H ₂ O)	Meter Temp 1 (°F)	Meter Vacuum 1 ("Hg)	Orifice dH 2 ("H ₂ O)	Meter Temp 2 (°F)	Meter Vacuum 2 ("Hg)	Dilution Tunnel (°F)	Tunnel Center dP	Pro. Rate 1	Pro. Rate 2	Scale Reading	Weight Change	Stack	Filter 1	Dryer 1	Filter 2	Dryer 2	Ambient	Draft ("H ₂ O)	CO ₂ (%)	CO (%)
343	55.281	56.231	0.16	0.16	1.33	79	2.02	1.09	80	1.10	96	0.055	99	99	18.9	0.0	241	73	68	73	69	68	-0.028	1.26	0.023
344	55.443	56.395	0.16	0.16	1.33	79	2.02	1.09	80	1.10	96	0.055	100	99	18.9	0.0	240	73	68	73	69	69	-0.027	2.17	0.009
345	55.604	56.559	0.16	0.16	1.33	79	2.02	1.09	80	1.10	96	0.055	99	99	18.8	-0.1	239	73	68	73	69	68	-0.026	1.77	0.018
346	55.766	56.723	0.16	0.16	1.33	79	2.01	1.09	80	1.10	96	0.056	99	99	18.8	0.0	241	73	68	73	69	69	-0.027	1.87	0.028
347	55.927	56.888	0.16	0.16	1.33	79	2.02	1.09	80	1.10	96	0.055	99	100	18.7	-0.1	243	73	68	73	69	69	-0.028	1.77	0.025
348	56.088	57.051	0.16	0.16	1.33	79	2.01	1.08	80	1.10	96	0.054	100	100	18.7	0.0	243	73	68	73	69	69	-0.028	2.21	0.013
349	56.249	57.215	0.16	0.16	1.33	79	2.01	1.09	80	1.10	96	0.056	99	99	18.7	0.0	244	73	68	73	69	69	-0.028	1.74	0.023
350	56.411	57.379	0.16	0.16	1.34	80	2.01	1.09	80	1.10	96	0.055	100	99	18.7	0.0	243	73	68	73	69	69	-0.027	2.44	0.009
351	56.572	57.543	0.16	0.16	1.34	80	2.01	1.09	80	1.10	97	0.055	99	100	18.6	-0.1	245	74	68	73	69	69	-0.027	1.90	0.013
352	56.733	57.707	0.16	0.16	1.33	80	2.02	1.09	80	1.10	97	0.055	99	100	18.6	0.0	246	74	68	73	69	69	-0.027	2.39	0.008
353	56.894	57.872	0.16	0.16	1.34	80	2.02	1.09	80	1.10	97	0.055	99	100	18.6	0.0	244	74	68	74	69	70	-0.028	1.62	0.026
354	57.056	58.035	0.16	0.16	1.33	80	2.02	1.09	80	1.10	97	0.056	99	98	18.5	-0.1	247	74	68	74	69	70	-0.028	1.93	0.011
355	57.217	58.199	0.16	0.16	1.34	80	2.01	1.08	80	1.10	97	0.055	99	100	18.5	0.0	242	74	68	74	69	70	-0.026	1.97	0.014
356	57.378	58.363	0.16	0.16	1.33	80	2.02	1.09	80	1.10	97	0.055	99	100	18.4	-0.1	244	74	68	74	69	70	-0.027	1.65	0.024
357	57.540	58.527	0.16	0.16	1.34	80	2.02	1.09	80	1.10	97	0.054	101	100	18.4	0.0	243	74	68	74	69	70	-0.029	1.95	0.006
358	57.701	58.690	0.16	0.16	1.34	80	2.01	1.09	80	1.10	97	0.055	99	99	18.4	0.0	243	74	68	74	69	70	-0.027	2.02	0.015
359	57.862	58.855	0.16	0.16	1.33	80	2.01	1.08	80	1.10	97	0.055	99	100	18.3	-0.1	241	74	68	74	69	70	-0.026	1.70	0.017
360	58.023	59.019	0.16	0.16	1.33	80	2.01	1.09	80	1.10	97	0.056	98	99	18.3	0.0	237	74	68	74	69	70	-0.026	1.59	0.024
Avg/Tot	58.023	59.019	0.16	0.16	1.34	79	2.00	1.09	79	1.10	99	0.05	100	100			280	74	71	74	70	69	-0.033	2.59	0.014

Pellet Heater Lab Data - ASTM E2779 / ASTM E2515

Manufacturer: Hearth & Home Equipment Numbers: _____
 Model: CB 1200I-C
 Tracking No.: 2332
 Project No.: 0061PM077E
 Run #: 1 Technician Signature: 
 Date: 12/18/18

TRAIN 1 (First Hour emissions)

Sample Component	Reagent	Filter, Probe or Seal #	Mass Readings		
			Tare, mg	Final, mg	Particulate, mg
A. Front filter catch	Filter	D633	120.2	121.2	1.0
B. Rear filter catch	Filter				0.0
C. Probe catch*	Probe				0.0
D. Filter seals catch*	Seals				0.0
1 st hour Sub-Total, mg:					1.0

TRAIN 1 (Remainder of Test)

Sample Component	Reagent	Filter, Probe or Seal #	Mass Readings		
			Tare, mg	Final, mg	Particulate, mg
A. Front filter catch	Filter	D634	122.1	125.3	3.2
B. Rear filter catch	Filter	D635	121.1	121.1	0.0
C. Probe catch*	Probe	35	114326.4	114326.4	0.0
D. Filter seals catch*	Seals	R697	3303.7	3304.2	0.5
Remainder Sub-Total, mg:					3.7
Train 1 Aggregate, mg:					4.7

TRAIN 2

Sample Component	Reagent	Filter, Probe or Seal #	Mass Readings		
			Tare, mg	Final, mg	Particulate, mg
A. Front filter catch	Filter	D636	121.0	125.5	4.5
B. Rear filter catch	Filter	D637	121.4	120.5	-0.9
C. Probe catch*	Probe	36	114883.4	114883.4	0.0
D. Filter seals catch*	Seals	R698	3402.9	3404.2	1.3
Train 2 Aggregate, mg:					4.9

AMBIENT

Sample Component	Reagent	Filter, Probe or Seal #	Mass Readings		
			Tare, mg	Final, mg	Particulate, mg
A. Front filter catch*	Filter				0.0
Ambient Aggregate, mg:					0.0

*Particulate catch that results in a negative number, is assumed to be zero for probes and seals, negative numbers for filters are assumed to be included in O-ring seal weights.

Pellet Heater Certification Run Sheets

Client: Hearth & Home Project Number: 0061PN013E Run Number: 1
 Model: Classic Bay 12001-C Tracking Number: 2332 Date: 12/18/18
 Test Crew: B. Davis
 OMNI Equipment ID numbers: 132, 283A, 335, 336, 410, 594, 559

ASTM E2515 Sampling Information

Test Location: Omni Portland Clock Time @ ET=0: 10:57
 Span Gas Concentrations: CO₂(%): 10.08 CO(%): 2.53 CO(ppm): 901

Test Run Validation Checks	Pre Test	Post Test
Zero Stack Gas Leakage	<u>good</u>	<u>good</u>
Zero Pitot Line Leakage	<u>good</u>	<u>good</u>
Zero Induced Draft	<u>good</u>	
100% Smoke Capture	<u>100%</u>	

Test Run Validation Measurements	Pre Test		Post Test	
Scale Audit (lbs)	<u>10.0</u>			
CO ₂ % (Zero/Span)	<u>0.00</u>	<u>10.08</u>	<u>0.00</u>	<u>10.12</u>
CO % (Zero/Span)	<u>0.000</u>	<u>2.518</u>	<u>0.000</u>	<u>2.524</u>
CO ppm (Zero/Span)	<u>0</u>	<u>905</u>	<u>0</u>	<u>901</u>
Sample A Leakage (cfm @"Hg)			<u>0.0</u>	<u>@ 10</u>
Sample B Leakage (cfm @"Hg)			<u>0.0</u>	<u>@ 7</u>
Room Air Velocity (ft/min)	<u>< 50</u>			
Barometric Pressure ("Hg)	<u>30.01</u>		<u>30.02</u>	
Relative Humidity (%)	<u>41.3</u>		<u>38.7</u>	
Tunnel Static ("H ₂ O)	<u>-.22</u>		<u>-.22</u>	

Last Cleaning Dates

Flue Pipe	<u>12/18/18</u>
Dilution Tunnel	<u>12/18/18</u>
Sample Dryers	<u>12/18/18</u>

Dilution Tunnel Traverse

Traverse Point	1	2	Center	3	4	5	6	7	8
Δp ("H ₂ O)	<u>.038</u>	<u>.050</u>	<u>.054</u>	<u>.046</u>	<u>.036</u>	<u>.036</u>	<u>.048</u>	<u>.050</u>	<u>.036</u>
T (°F)	<u>116</u>	<u>117</u>	<u>117</u>	<u>117</u>	<u>117</u>	<u>117</u>	<u>117</u>	<u>117</u>	<u>117</u>

Technician Signature: B. Davis

Date: 1/24/19

Pellet Heater Certification Run Sheets

Client: Hearth & Home Project Number: 0061PN013E Run Number: 1
 Model: Classic Bay 12001-C Tracking Number: 2332 Date: 12/18/18
 Test Crew: B. Davis
 OMNI Equipment ID numbers: _____

ASTM E2779 Run Notes

Air Control Settings

High Burn Rate Target: 100%

Settings: FRAP Rod fully open, Heat setting on High, Fan on, Automatic to Heat setting, Control board set on #2

Medium Burn Rate Target: <50%

Settings: FRAP Rod fully closed, Heat setting on Low, Control board on #2

Low Burn Rate Target: Minimum

Settings: FRAP Rod fully closed, Heat setting on Low, Control board on #1.

Additional Settings Notes:

None

Pellet Moisture Content: 6.27

Pellet Specifications: Softwood Pellets

Pellet Analysis Notes: Report No. USR:W218-1227-01

Preburn Notes

Time	Notes
<u>0</u> <u>42</u>	<u>FRAP Rod fully open, Heat setting on High, Fan operation Automatic to Heat setting</u> <u>Added clamp to stove due to broken fire holder, weight = 1.7 pounds.</u>

Test Notes

Time	Notes
<u>60</u> <u>180</u>	<u>Changed filter in train A. Changed Heat setting to Low, control board on #2</u> <u>FRAP Rod Full closed</u> <u>changed control board setting to #1.</u>

Technician Signature: B. Davis

Date: 1/24/19

2.2 - Sample Analysis & Tares

Analysis Worksheets
Tared Filter, Probe, and O-Ring Data
Pellet Fuel Label
Pellet Fuel Analysis Report

Pellet Heater Certification Run Sheets

Client: Hearth & Home Project Number: 0061PN013E Run Number: 1
 Model: Classic Bay 12001-C Tracking Number: 2332 Date: 12/18/18
 Test Crew: B. Davis
 OMNI Equipment ID numbers: 592, 637, 283A

ASTM E2515 Lab Sheet

Assembled By:

B Davis

Date/Time in Desiccator:

12/18/18 1645

Weighing #1	Weighing #2	Weighing #3	Weighing #4
Date: <u>12/20/18</u>	Date: <u>12/21/18</u>	Date:	Date:
Time: <u>0804</u>	Time: <u>0940</u>	Time:	Time:
R/H %: <u>14.3</u>	R/H %: <u>13.5</u>	R/H %:	R/H %:
Temp (F): <u>67.4</u>	Temp (F): <u>67.1</u>	Temp (F):	Temp (F):
Audit 1: <u>200.1</u>	Audit 1: <u>200.0</u>	Audit 1:	Audit 1:
Audit 2: <u>5000.0</u>	Audit 2: <u>5000.0</u>	Audit 2:	Audit 2:
Audit 3: <u>99998.1</u>	Audit 3: <u>99998.0</u>	Audit 3:	Audit 3:
Initials: <u>BA</u>	Initials: <u>BA</u>	Initials:	Initials:

Train	Item	ID #	Tare (mg)	Weight (mg)	Weight (mg)	Weight (mg)	Weight (mg)
A	Front Filter (60 min)	<u>D633</u>	<u>120.2</u>	<u>121.4</u>	<u>121.2</u>	-	
A	Front Filter (Remainder)	<u>D634</u>	<u>122.1</u>	<u>125.5</u>	<u>125.3</u>	-	
A	Rear Filter	<u>D635</u>	<u>121.1</u>	<u>121.3</u>	<u>121.1</u>	-	
A	Probe	<u>35</u>	<u>114326.4</u>	<u>114326.2</u>	<u>114326.4</u>	-	
A	O-Ring Set	<u>R697</u>	<u>3303.7</u>	<u>3304.3</u>	<u>3304.2</u>	-	
B	Front Filter	<u>D636</u>	<u>121.0</u>	<u>125.6</u>	<u>125.5</u>	-	
B	Rear Filter	<u>D637</u>	<u>121.4</u>	<u>120.7</u>	<u>120.5</u>	-	
B	Probe	<u>36</u>	<u>114883.4</u>	<u>114883.4</u>	<u>114883.4</u>	-	
B	O-Ring Set	<u>R698</u>	<u>3402.9</u>	<u>3404.3</u>	<u>3404.2</u>	-	
BG	Filter						

Technician Signature: 

Date: 1/24/19

Tare Sheet: (check one)

Probes _____

47mm Filters

100mm Filters _____

O-Ring Pair _____

Prepared By: B. Daus

Balance ID #: OMMI-00637

Thermohygrometer ID #: OMMI-00592

Audit Weight ID #/Mass: OMMI-00257-A / 200.0

Placed in Dessicator: Date: <u>12/13/18</u> Time: <u>10:20</u>	Date: <u>12/14/18</u> Time: <u>10:40</u> RH %: <u>10.7</u> T (°F): <u>67.4</u> Audit: <u>200.0</u>	Date: <u>12/17/18</u> Time: <u>12:20</u> RH %: <u>13.2</u> T (°F): <u>66.9</u> Audit: <u>200.0</u>	Date: _____ Time: _____ RH %: _____ T (°F): _____ Audit: _____	Date: _____ Time: _____ RH %: _____ T (°F): _____ Audit: _____	Date Used	Project Number	Run No.
	ID #	Audit: <u>200.0</u>	Audit: <u>200.0</u>	Audit: _____			
D633	120.1	120.2	-		12/13/18 ↓ 0061PN013E ↓ 1		
D634	122.0	122.1	-				
D635	121.3	121.1	-				
D636	121.0	121.0	-				
D637	121.3	121.4	-				
D638	121.2	121.3	-				
D639	120.7	120.6	-				
D640	121.0	121.1	-				
D641	121.1	121.1	-				
D642	121.6	121.5	-				
D643	121.5	121.5	-				
D644	120.8	120.9	-				
D645	120.7	120.8	-				
D646	121.6	121.5	-				
D647	121.2	121.1	-				
D648	120.6	120.6	-				
D649	121.3	121.2	-				
D650	122.0	122.0	-				
D651	121.2	121.0	-				
D652	120.5	120.4	-				
Initials: <u>DA</u>	Initials: <u>DL</u>	Initials: _____	Initials: _____	Initials: _____			

Final Technician Signature: [Signature]

Date: 12/17/18

Evaluator signature: [Signature]

Tare Sheet: (check one)

Probes _____

47mm Filters _____

100mm Filters _____

O-Ring Pair

Prepared By: B. Davis

Balance ID #: Omni-00637

Thermohyrometer ID #: Omni 00592

Audit Weight ID #/Mass: Omni-002534

1 5g

Placed in Dessicator: Date: <u>12/10/18</u> Time: <u>0910</u>	Date: <u>12/13/18</u> Time: <u>10:13</u> RH %: <u>11.1</u> T (°F): <u>67.4</u> Audit: <u>4999.9</u>	Date: <u>12/14/18</u> Time: <u>0920</u> RH %: <u>11.2</u> T (°F): <u>66.4</u> Audit: <u>5000.0</u>	Date: <u>12/17/18</u> Time: <u>0850</u> RH %: <u>10.8</u> T (°F): <u>65.2</u> Audit: <u>5000.0</u>	Date: _____ Time: _____ RH %: _____ T (°F): _____ Audit: _____	Date Used	Project Number	Run No.
	ID #						
R695	3413.2	3413.4	-				
R696	3265.9	3266.0	-				
R697	3303.5	3303.7	-		12/18/18	0061 PN 013 E	1
R698	3402.6	3403.0	3402.9		↓	↓	↓
R699	3319.7	3319.7	-				
R700	4137.9	4138.1	✓				
R701	4074.9	4075.0	-				
R702	4075.9	4075.9	-				
R703	3307.2	3307.6	3307.4				
R704	3304.5	3304.6	-				
R705	4095.1	4095.0	✓				
R706	3343.8	3344.1	3343.9				
R707	4112.8	4112.8	-				
R708	4112.7	4112.7	-				
R709	3413.6	3413.9	3413.9				
R710	3547.3	3547.6	3547.4				
Initials: <u>BD</u>	Initials: <u>BD</u>	Initials: <u>BD</u>	Initials: _____				

Final Technician Signature:

Date: 12/17/18

Evaluator signature:

THE ORIGINAL
Pres-to-Logs[®] WOOD PELLET FUEL

THE ORIGINAL
Pres-to-Logs[®]

**COMBUSTIBLE DE GRÁNULOS
DE MADERA Pres-to-Logs**[®]

Premium Quality

MADE FROM PURE WESTERN CONIFER SAWDUST

Primera Calidad

HECHO DE ASERRÍN PURO DE CONIFERAS OCCIDENTALES

**WOOD
PELLET
FUEL**

**COMBUSTIBLE
DE GRÁNULOS
DE MADERA**

- Clean/Limpio
- Efficient/Eficiente
- Economical/Económico

**California Proposition 65
WARNING**

This product contains wood dust, a substance known to the State of California to cause cancer, in addition, combustion of wood products, like wood products, result in the emission of carbon monoxide, and other air pollution by-products which are known by the State of California to cause cancer, birth defects, or other reproductive harm. Use a dust mask and eye goggles to avoid inhaling wood dust or wood combustion by-products.

 **PRE-GRADED FUEL**

PFI Certified Fuel Grader Premium
MFI Registration # 03208
Grade Requirements:

Bulk Density:	43-48 lb/ft ³
Diameter:	33-35 or 5.84-7.25 mm
Durability:	≥96.5
Fines:	≤0.5%
Ash Content (as received):	≤1%
Length:	≤1% >1.5 in.
Moisture:	≤8.0%
Chlorides:	≤300 ppm

Manufacturers Guaranteed Analysis:

Type of Material:	Softwood
Solubles:	None
Minimum Higher Heating Value (as received):	8200 BTU/lb.

Other Manufacturers Guarantees:



For more information, please visit the PFI website at www.pelletfuel.org

Pres-to-Logs[®] Pellet Fuel must be burned in a stove or furnace designed to burn wood pellets. Pres-to-Logs[®] is not responsible for damages from improper burning of this fuel.

El Combustible en Gránulos Pres-to-Logs[®] debe utilizarse en una estufa u horno diseñados para gránulos de madera. Pres-to-Logs[®] no se hace responsable por daños ocasionados por el uso incorrecto de este combustible.



**NET WT. 40 lbs. (18 kg)
PESO NETO 40 lbs. (18 kg)**





PFI Densified Fuel Grade: Premium
Mill Registration # 03208
Grade Requirements:

Bulk Density:	40-48 lbs/ft ³
Diameter:	.230-.285 in/5.84-7.25 mm
Durability:	≥96.5
Fines:	≤0.50%
Ash Content (as received):	≤1%
Length:	≤1% >1.5 in.
Moisture:	≤8.0%
Chlorides:	≤300 ppm

Manufacturers Guaranteed Analysis:

Type of Material:	Softwood
Additives:	None
Minimum Higher Heating Value (as received):	8200 BTU/lb.
Other Manufacturers Guarantees:	



© For more information, please visit the PFI website at www.pelletheat.org.

Pres-to-Logs® Pellet
furnace designed
is not responsible
burning of this fuel
El Combustible en
en una estufa u h
Pres-to-Logs® no s
por el uso incorre

NET WT
PESO NETO



Twin Ports Testing, Inc.
 1301 North 3rd Street
 Superior, WI 54880
 p: 715-392-7114
 p: 800-373-2562
 f: 715-392-7163
 www.twinportstesting.com

Report No: USR:W218-1227-01
Issue No: 1

Analytical Test Report

Client: OMNI-TEST LABORATORIES INC.
 13327 NE Airport Way
 Portland, OR 97230
Attention: Finance Department
PO No: 180206

Signed: *Katy Jahr*
 Katy Jahr
 Chemistry Lab Supervisor
 Date of Issue: 1/8/2019
THIS DOCUMENT SHALL NOT BE REPRODUCED EXCEPT IN FULL

Sample Details
Sample Log No: W218-1227-01 **Sample Date:**
Sample Designation: 013E-077E **Sample Time:**
Sample Recognized As: Wood Pellets **Arrival Date:** 12/27/2018

Test Results

	METHOD	UNITS	MOISTURE FREE	AS RECEIVED
Moisture Total	ASTM E871	wt. %		6.27
Ash	ASTM D1102	wt. %	0.26	0.25
Volatile Matter	ASTM D3175	wt. %		
Fixed Carbon by Difference	ASTM D3172	wt. %		
Sulfur	ASTM D4239	wt. %	0.006	0.006
SO ₂	Calculated	lb/mmbtu		0.014
Net Cal. Value at Const. Pressure	ISO 1928	GJ/tonne	19.80	18.41
Net Cal. Value at Const. Pressure	ISO 1928	J/g	19803	18408
Gross Cal. Value at Const. Vol.	ASTM E711	J/g	21092	19770
Gross Cal. Value at Const. Vol.	ASTM E711	Btu/lb	9069	8500
Carbon	ASTM D5373	wt. %	51.57	48.33
Hydrogen*	ASTM D5373	wt. %	5.92	5.55
Nitrogen	ASTM D5373	wt. %	< 0.21	< 0.19
Oxygen*	ASTM D3176	wt. %	> 42.04	> 39.40

*Note: As received values do not include hydrogen and oxygen in the total moisture.

Chlorine	ASTM D6721	mg/kg		
Fluorine	ASTM D3761	mg/kg		
Mercury	ASTM D6722	mg/kg		

Bulk Density	ASTM E873	lbs/ft ³		
Fines (Less than 1/8")	TPT CH-P-06	wt. %		
Durability Index	Kansas State	PDI		
Sample Above 1.50"	TPT CH-P-06	wt. %		
Maximum Length (Single Pellet)	TPT CH-P-06	inch		
Diameter, Range	TPT CH-P-05	inch		to
Diameter, Average	TPT CH-P-05	inch		
Stated Bag Weight	TPT CH-P-01	lbs		
Actual Bag Weight	TPT CH-P-01	lbs		

Comments

Section 3

Laboratory Quality Assurance

- 3.1 - Quality Assurance/Quality Control**
- 3.2 - Calibration Data**
- 3.3 - Example Calculations**

3.1 - Quality Assurance/Quality Control

OMNI follows the guidelines of ISO/IEC 17025, “General Requirements for the Competence of Testing and Calibration Laboratories,” and the quality assurance/quality control (QA/QC) procedures found in *OMNI*'s Quality Assurance Manual.

OMNI's scope of accreditation includes, but is not limited to, the following:

- ANSI (American National Standards Institute) for certification of product to safety standards.
- To perform product safety testing by the International Accreditation Service, Inc. (formerly ICBO ES) under accreditation as a testing laboratory designated TL-130.
- To perform product safety testing as a “Certification Organization” by the Standards Council of Canada (SCC).
- Serving as a testing laboratory for the certification of wood heaters by the U.S. Environmental Protection Agency.

This report is issued within the scope of *OMNI*'s accreditation. Accreditation certificates are available upon request.

The manufacturing facilities and quality control system for the production of the Classic Bay 1200I-C at Hearth & Home Technologies were evaluated to determine if sufficient to maintain conformance with *OMNI*'s requirements for product certification. *OMNI* has concluded that the manufacturing facilities, processes, and quality control system are adequate to produce the appliance congruous with the standards and model codes to which it was evaluated.

This report shall not be reproduced, except in full, without the written approval of *OMNI-Test Laboratories, Inc.*

3.2 - Calibration Data

Equipment for ASTM E2515, ASTM E2779, & EPA Method 28R

ID #	Lab Name/Purpose	Log Name	Attachment Type
132	10 lb Weight	Weight Standard, 10 lb.	Calibration Certificate
283A	Audit Weights	Troemner 21pc Msas Set	Calibration Certificate
335	Sample Box / Dry Gas Meter	Apex Automated Emissions Sampling Box	Calibration Log
336	Sample Box / Dry Gas Meter	Apex Automated Emissions Sampling Box	Calibration Log
410	Microtector	Dwyer Microtector	Calibration Certificate
594	Combustion Gas Analyzer	CAI Gas Analyzer	See Run Sheet
559	Vaneometer	Dwyer Vaneometer	Equipment Record
592	Thermohygrometer	Omega Digital Thermohygrometer	Calibration Log
637	Milligram Balance	Analytical Balance - Mettler - Toledo	Calibration Certificate
650	Barometer/Hygrometer	Digital Barometer	Calibration Certificate

SCALE WEIGHT CALIBRATION DATA SHEET

Weight to be calibrated: 10 pounds

ID Number: OMNI-00132

Standard Calibration Weight: 10 pounds

ID Number: OMNI-00255

Scale Used: MTW-150K

ID Number: OMNI-00353

Date: 2/23/2018

By: B. Davis

Standard Weight (A) (Lb.)	Weight Verified (B) (Lb.)	Difference (A - B)	% Error
10.0	10.0	0.0	0

*Acceptable tolerance is 1%.

This calibration is traceable to NIST using calibrated standard weights.

Technician signature:  Date: 2/23/18

Certificate of Calibration



JJ Calibrations, Inc.

7007 SE Lake Rd
Portland, OR 97267-2105
Phone 503.786.3005
FAX 503.786.2994

Certificate Number: **685888**

Omni-Test Laboratories
13327 NE Airport Way
Portland, OR 97230

PO: **180188**
Order Date: **10/09/2018**
Authorized By: **N/A**



Property #: **OMNI-00283A**
User: **N/A**
Department: **N/A**
Make: **Troemner Inc**
Model: **1mg-100g (Class F)**
Serial #: **47883**
Description: **Mass Set, 21pc**
Procedure: **DCN 500901**
Accuracy: **Class F**

Calibrated on: **10/26/2018**
*Recommended Due: **10/26/2023**
Environment: **20 °C 57 % RH**
* As Received: **Within Tolerance**
* As Returned: **Within Tolerance**
Action Taken: **Calibrated**
Technician: **139**

Remarks: * Many factors may cause the unit to drift out of calibration before the recommended due date. Any reported error is the absolute value between the reference and the unit. Uncertainties include the effects of the unit.

This set meets Class F specifications.
Received and returned eight (8) masses in a black case secured by a rubber band.

Standards Used

Std ID	Manufacturer	Model	Nomenclature	Due Date	Trace ID
723A	Rice Lake	1mg-200g (Class 0)	Mass Set,	03/23/2019	668240
800A	Sartorius	MSA225W100DI	Analytical Balance	12/11/2018	663857

Measurement Data

Parameter	Measurement Description	Range Unit	Reference	Min	Max	*Error	UUT	Uncertainty
Before/After								Accredited = ✓
Mass								
Dot	200 mg	200.00030	199.4603	200.5403	0.0500	200.0503 mg	6.2E-01	✓
	1 g	1.0000880	0.9991088	1.0009088	0.0000000	1.000088 g	1E-03	✓
	2 g	2.00001470	1.9989147	2.0011147	0.0003250	2.0003397 g	1.3E-03	✓
	5 g	5.00000840	4.9985084	5.0015084	0.0000400	4.9999684 g	1.7E-03	✓
	10 g	10.0000100	9.998010	10.002010	0.000245	9.999765 g	2.3E-03	✓
Dot	20 g	20.0000140	19.996014	20.004014	0.000990	20.001004 g	4.6E-03	✓
	50 g	49.9999660	49.989966	50.009966	0.000595	49.999371 g	1.1E-02	✓
	100 g	100.000000	99.98000	100.02000	0.00194	99.99806 g	2.3E-02	✓

JJ Calibrations, Inc. certifies that this instrument has been calibrated in accordance with the JJ Calibrations Quality Assurance Manual with the stated procedure using standards that are traceable to the National Institute of Standards and Technology (NIST), or other National Measurement Institutes (NMI's), or by using natural physical constants, intrinsic standards or ratio calibration techniques. The quality system and this certificate are in compliance with ANSI/NCCL Z540-1-1994, ISO/IEC 17025-2005, ISO 10012-1, the ISO 9000 family and QS 9000. The expanded uncertainties of measurements for this calibration are based upon 95% (2 sigma) confidence limits. Unless otherwise stated, a test accuracy ratio (TAR) of 4:1, if achievable, is maintained. The results reported herein apply only to the calibration of the item described above. This report may not be reproduced, except in full, without prior written consent of JJ Calibrations, Inc.
JJ Calibrations, Inc. quality system has been assessed and accredited to ISO/IEC 17025:2005.

Reviewer

3 Issued 10/29/2018 Rev # 15

Inspector

Thermal Metering System Calibration Y Factor

Manufacturer: APEX
 Model: XC-60-EP
 Serial Number: 606001
 OMNI Tracking No.: OMNI-00335
 Calibrated Orifice:

Average Gas Meter y Factor
0.986

Orifice Meter dH@
N/A

Calibration Date: 07/17/18
 Calibrated by: B. Davis
 Calibration Frequency: Six months
 Next Calibration Due: 1/17/2019
 Instrument Range: 1.000 cfm
 Standard Temp.: 68 oF
 Standard Press.: 29.92 "Hg
 Barometric Press., Pb: 30.12 "Hg
 Signature/Date: *B. Davis* 7/18/2018

Previous Calibration Comparison

Date	<u>1/17/2018</u>	Acceptable Deviation (5%)	Deviation
y Factor	<u>0.977</u>	0.04885	0.009
Acceptance	Acceptable		

Current Calibration

Acceptable y Deviation	0.020
Maximum y Deviation	0.008
Acceptable dH@ Deviation	N/A
Maximum dH@ Deviation	N/A
Acceptance	Acceptable

Reference Standard *

Standard	Model	Standard Test Meter
Calibrator	S/N	<u>OMNI-00001</u>
	Calib. Date	<u>30-Oct-17</u>
	Calib. Value	<u>0.9977</u> y factor (ref)

Calibration Parameters	Run 1	Run 2	Run 3
Reference Meter Pressure ("H2O), Pr	<u>0.00</u>	<u>0.00</u>	<u>0.00</u>
DGM Pressure ("H2O), Pd	<u>2.00</u>	<u>1.38</u>	<u>1.00</u>
Initial Reference Meter	<u>609.1</u>	<u>615.5</u>	<u>620.8</u>
Final Reference Meter	<u>615.4</u>	<u>620.7</u>	<u>626.7</u>
Initial DGM	<u>0</u>	<u>0</u>	<u>0</u>
Final DGM	<u>6.292</u>	<u>5.245</u>	<u>5.995</u>
Temp. Ref. Meter (°F), Tr	<u>92.0</u>	<u>93.0</u>	<u>91.0</u>
Temperature DGM (°F), Td	<u>92.0</u>	<u>93.0</u>	<u>91.0</u>
Time (min)			
Net Volume Ref. Meter, Vr	6.300	5.200	5.900
Net Volume DGM, Vd	6.292	5.245	5.995
Gas Meter y Factor =	0.994	0.986	0.979
Gas Meter y Factor Deviation (from avg.)	0.008	0.001	0.007
Orifice dH@	N/A	N/A	N/A
Orifice dH@ Deviation (from avg.)	N/A	N/A	N/A

where:

1. Deviation = |Average value for all runs - current run value|
- ** 2. $y = [Vr \times (y \text{ factor (ref)}) \times (Pb + (Pr / 13.6)) \times (Td + 460)] / [Vd \times (Pb + (Pd / 13.6)) \times (Tr + 460)]$
- ** 3. $dH@ = 0.0317 \times Pd / (Pb (Td + 460)) \times [(Tr + 460) \times \text{time}] / Vr]^2$

* Reference calibration is traceable to NIST through NIST Test # 40674, Kimble ASTM E1272, or NIST traceable laboratory

** Equations come from EPA Method 5

The uncertainty of measurement is $\pm 0.14 \text{ ft}^3/\text{min}$. This is based on the reference standard having a TAR (Test Accuracy Ratio) of at least 4:1.

DIFFERENTIAL PRESSURE GAUGE CALIBRATION DATA SHEET

Instrument to be calibrated: Pressure Transducer

Maximum Range: 0-2" WC ID Number: OMNI-00335

Calibration Instrument: Digital Manometer ID Number: OMNI-00395

Date: 7/18/2018 By: B. Davis

This form is to be used only in conjunction with Standard Procedure C-SPC.

Range of Calibration Point ("WC)	Digital Manometer Input ("WC)	Pressure Gauge Response ("WC)	Difference (Input - Response)	% Error of Full Span*
0-20% Max. Range 0 - 0.4	0.183	0.183	0.0	0.0
20-40% Max. Range 0.4 - 0.8	0.705	0.704	0.001	0.05
40-60% Max. Range 0.8 - 1.2	1.019	1.016	0.003	0.15
60-80% Max. Range 1.2 - 1.6	1.394	1.391	0.003	0.15
80-100% Max. Range 1.6 - 2.0	1.980	1.978	0.002	0.10

*Acceptable tolerance is 4%.

The uncertainty of measurement is ± 0.4 " WC. This is based on the reference standard having a TAR (Test Accuracy Ratio) of at least 4:1.

Technician signature:  Date: 7/18/18



Reviewed by:  Date: 7/20/18

Temperature Calibration EPA Method 28R, ASTM 2515								
BOOTH:		TEMPERATURE MONITOR TYPE:				EQUIPMENT NUMBER:		
Mobile		National Instruments Logger				00335, 00336		
REFERENCE METER EQUIPMENT NUMBER: 00373				Calibration Due Date: 8/02/17				
CALIBRATION PERFORMED BY:			DATE:		AMBIENT TEMPERATURE:		BAROMETRIC PRESSURE:	
B. Davis			7/17/18		76		30.12	
Input Temperature (F)	Ambient	Meter A					Tunnel	FB Interior
			Meter B	Filter A	Filter B			
0	0	1	1	1	1	0	0	
100	100	101	101	100	100	100	100	
300	300	300	300	300	300	300	300	
500	500	501	500	500	500	500	500	
700	700	700	700	700	700	700	700	
1000	1000	1001	1000	1000	1000	1000	1000	

Input (F)	FB Top	FB Bottom	FB Back	FB Left	FB Right	Imp A	Imp B	Cat	Stack
0	0	0	0	0	0	1	1	1	0
100	100	100	100	100	100	101	101	101	100
300	300	300	300	300	300	300	300	300	300
500	500	500	500	500	500	500	500	500	500
700	700	700	700	700	700	700	700	700	700
1000	1000	1000	1000	1000	1000	1000	1000	1000	1000

1500
2000

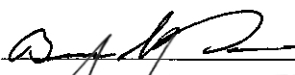
1500
2000

Technician signature:  Date: 7/17/18
 Reviewed By:  Date: 7/20/18

Thermal Metering System Calibration Y Factor

Manufacturer: APEX
 Model: XC-60-EP
 Serial Number: 606002
 OMNI Tracking No.: OMNI-00336
 Calibrated Orifice:

Average Gas Meter y Factor
0.985

Orifice Meter dH@
N/A

Calibration Date: 07/17/18
 Calibrated by: B. Davis
 Calibration Frequency: Six months
 Next Calibration Due: 1/17/2019
 Instrument Range: 1.000 cfm
 Standard Temp.: 68 oF
 Standard Press.: 29.92 "Hg
 Barometric Press., Pb: 30.12 "Hg
 Signature/Date: *B. Davis* 1/17/2018

Previous Calibration Comparison

Date	<u>1/17/2018</u>	Acceptable Deviation (5%)	Deviation
y Factor	<u>0.979</u>	0.04895	0.006
Acceptance	Acceptable		

Current Calibration

Acceptable y Deviation	0.020
Maximum y Deviation	0.003
Acceptable dH@ Deviation	N/A
Maximum dH@ Deviation	N/A
Acceptance	Acceptable

Reference Standard *

Standard	Model	Standard Test Meter
Calibrator	S/N	<u>OMNI-00001</u>
	Calib. Date	<u>30-Oct-17</u>
	Calib. Value	<u>0.9977</u> y factor (ref)

Calibration Parameters	Run 1	Run 2	Run 3
Reference Meter Pressure ("H2O), Pr	0.00	0.00	0.00
DGM Pressure ("H2O), Pd	1.91	1.20	0.80
Initial Reference Meter	572.4	577.5	582.9
Final Reference Meter	577.4	582.604	588.1
Initial DGM	0	0	0
Final DGM	5.061	5.245	5.34
Temp. Ref. Meter (°F), Tr	86.0	86.0	78.0
Temperature DGM (°F), Td	90.0	95.0	86.0
Time (min)	23.5	30.0	37.8
Net Volume Ref. Meter, Vr	5.000	5.104	5.200
Net Volume DGM, Vd	5.061	5.245	5.34
Gas Meter y Factor =	0.988	0.984	0.984
Gas Meter y Factor Deviation (from avg.)	0.003	0.001	0.001
Orifice dH@	N/A	N/A	N/A
Orifice dH@ Deviation (from avg.)	N/A	N/A	N/A

where:

1. Deviation = |Average value for all runs - current run value|
- ** 2. $y = [V_r \times (y \text{ factor (ref)}) \times (P_b + (P_r / 13.6)) \times (T_d + 460)] / [V_d \times (P_b + (P_d / 13.6)) \times (T_r + 460)]$
- ** 3. $dH@ = 0.0317 \times P_d / (P_b (T_d + 460)) \times [(T_r + 460) \times \text{time}] / V_r]^2$

* Reference calibration is traceable to NIST through NIST Test # 40674, Kimble ASTM E1272, or NIST traceable laboratory

** Equations come from EPA Method 5

The uncertainty of measurement is ±0.14 ft³/min. This is based on the reference standard having a TAR (Test Accuracy Ratio) of at least 4:1.

DIFFERENTIAL PRESSURE GAUGE CALIBRATION DATA SHEET

Instrument to be calibrated: Pressure Transducer

Maximum Range: 0-2" WC ID Number: OMNI-00336

Calibration Instrument: Digital Manometer ID Number: OMNI-00395

Date: 7/18/18 By: B. Davis

This form is to be used only in conjunction with Standard Procedure C-SPC.

Range of Calibration Point ("WC)	Digital Manometer Input ("WC)	Pressure Gauge Response ("WC)	Difference (Input - Response)	% Error of Full Span*
0-20% Max. Range 0 - 0.4	0.045	0.041	0.003	0.20
20-40% Max. Range 0.4 - 0.8	0.446	0.447	0.001	0.05
40-60% Max. Range 0.8 - 1.2	0.900	0.901	0.001	0.05
60-80% Max. Range 1.2 - 1.6	1.589	1.592	0.003	0.20
80-100% Max. Range 1.6 - 2.0	1.902	1.908	0.006	0.30

*Acceptable tolerance is 4%.

The uncertainty of measurement is ± 0.4 " WC. This is based on the reference standard having a TAR (Test Accuracy Ratio) of at least 4:1.

Technician signature:  Date: 7/18/18

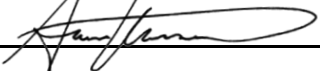
Reviewed by:  Date: 7/20/18

Temperature Calibration EPA Method 28R, ASTM 2515								
BOOTH:		TEMPERATURE MONITOR TYPE:				EQUIPMENT NUMBER:		
Mobile		National Instruments Logger				00335, 00336		
REFERENCE METER EQUIPMENT NUMBER: 00373				Calibration Due Date: 8/02/17				
CALIBRATION PERFORMED BY:			DATE:		AMBIENT TEMPERATURE:		BAROMETRIC PRESSURE:	
B. Davis			7/17/18		76		30.12	
Input Temperature (F)	Ambient	Meter A					Tunnel	FB Interior
			Meter B	Filter A	Filter B			
0	0	1	1	1	1	0	0	
100	100	101	101	100	100	100	100	
300	300	300	300	300	300	300	300	
500	500	501	500	500	500	500	500	
700	700	700	700	700	700	700	700	
1000	1000	1001	1000	1000	1000	1000	1000	

Input (F)	FB Top	FB Bottom	FB Back	FB Left	FB Right	Imp A	Imp B	Cat	Stack
0	0	0	0	0	0	1	1	1	0
100	100	100	100	100	100	101	101	101	100
300	300	300	300	300	300	300	300	300	300
500	500	500	500	500	500	500	500	500	500
700	700	700	700	700	700	700	700	700	700
1000	1000	1000	1000	1000	1000	1000	1000	1000	1000

1500
2000

1500
2000

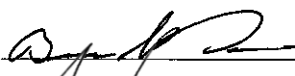
Technician signature:  Date: 7/17/18

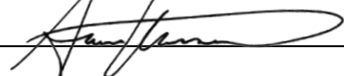
Reviewed By:  Date: 7/20/18

Certificate of Calibration

Certificate Number: **686722**



JJ Calibrations, Inc.
 7007 SE Lake Rd
 Portland, OR 97267-2105
 Phone 503.786.3005
 FAX 503.786.2994

Omni-Test Laboratories
 13327 NE Airport Way
 Portland, OR 97230



PO: **180192**
 Order Date: **10/22/2018**
 Authorized By: **N/A**
 Calibrated on: **10/30/2018**
 *Recommended Due: **10/30/2019**
 Environment: **22 °C 44 % RH**
 * As Received: **Limited**
 * As Returned: **Limited**
 Action Taken: **Calibrated**
 Technician: **111**

Property #: **OMNI-00410**
 User: **N/A**
 Department: **N/A**
 Make: **Dwyer**
 Model: **1430**
 Serial #: **OMNI-00410**
 Description: **Microtector**
 Procedure: **DCN 500908**
 Accuracy: **±0.00025" WC**

Remarks: * Many factors may cause the unit to drift out of calibration before the recommended due date. Any reported error is the absolute value between the reference and the unit. Uncertainties include the effects of the unit.

Previous limitation of micrometer head calibrated only continued. .001" reading micrometer head ±.001" (LSD) tolerance applied.

Standards Used

Std ID	Manufacturer	Model	Nomenclature	Due Date	Trace ID
541A	Select	E8FED2	Gage Block Set, 8pc	12/18/2018	663864

Measurement Data

Parameter	Measurement Description	Range	Unit	Reference	Min	Max	*Error	UUT	Uncertainty
Before/After Length			Inch	0.1300	0.129	0.131	0.001	0.129 Inch	1.1E-03 ✓
			Inch	0.3850	0.384	0.386	0.001	0.384 Inch	1.1E-03 ✓
			Inch	0.6150	0.614	0.616	0.001	0.614 Inch	1.1E-03 ✓
			Inch	0.8700	0.869	0.871	0.001	0.869 Inch	1.1E-03 ✓
			Inch	1.0000	0.999	1.001	0.001	0.999 Inch	1.1E-03 ✓

JJ Calibrations, Inc. certifies that this instrument has been calibrated in accordance with the JJ Calibrations Quality Assurance Manual with the stated procedure using standards that are traceable to the National Institute of Standards and Technology (NIST), or other National Measurement Institutes (NMI's), or by using natural physical constants, intrinsic standards or ratio calibration techniques. The quality system and this certificate are in compliance with ANSI/NC SL Z540-1-1994, ISO/IEC 17025-2005, ISO 10012-1, the ISO 9000 family and QS 9000. The expanded uncertainties of measurements for this calibration are based upon 95% (2 sigma) confidence limits. Unless otherwise stated, a test accuracy ratio (TAR) of 4:1, if achievable, is maintained. The results reported herein apply only to the calibration of the item described above. This report may not be reproduced, except in full, without prior written consent of JJ Calibrations, Inc.
 JJ Calibrations, Inc. quality system has been assessed and accredited to ISO/IEC 17025:2005.

 Reviewer

3 Issued 10/31/2018 Rev # 15

 Inspector

ZRE

NDIR/O₂



USER'S

MANUAL



1312 West Grove Avenue
Orange, CA 92865-4134
Phone: 714-974-5560 Fax: 714-921-2531
www.gasanalyzers.com

VWR Temperature Hygrometer Calibration Procedure and Data Sheet

Frequency: Every Two Years

Step 1: Locate NIST traceable standard.

Step 2: Place unit to be calibrated, tracking No. OMNI-00592, inside OMNI desiccate box on the same shelf with the NIST traceable standard.

Step 3: After a period of not less than four hours record the temperature and humidity of both units in the spaces provide below.

Step 4: If the unit to be calibrated matches the NIST standard within $\pm 4\%$, it is acceptable. If not, the unit needs to be sent to a repair company or replaced.

Verification Data:

Date: 1/8/2018 Technician: B Davis

Time in desiccate: 0910 Recording time: 1335

NIST Standard Temperature: 28.3 °F NIST Standard Humidity: 74.5

Test Unit Temperature Reading: 25.4 °F Test Unit Humidity Reading: 74.3

Test unit OMNI- 00592 is X or was not within acceptable limits.

Technician Signature: 

Comments: Full scale of OMNI-00592 is 90% RH, with a difference of 2.9 this gives a error percentage of 3.22%. This value is within the allowable 4%.

Certificate of Calibration

Certificate Number: **681844**



JJ Calibrations, Inc.
 7007 SE Lake Rd
 Portland, OR 97267-2105
 Phone 503.786.3005
 FAX 503.786.2994

Omni-Test Laboratories
 13327 NE Airport Way
 Portland, OR 97230

OnSite

PO: **180176**
 Order Date: **08/07/2018**
 Authorized By: **N/A**



Calibrated on: **08/07/2018**
 *Recommended Due: **02/07/2019**
 Environment: **22 °C 38 % RH**
 * As Received: **Out of Tolerance**
 * As Returned: **Within Tolerance**
 Action Taken: **Adjusted**
 Technician: **III**

Property #: **OMNI-00637**
 User: **N/A**
 Department: **N/A**
 Make: **Mettler Toledo**
 Model: **MS104TS/00**
 Serial #: **B729400181**
 Description: **Analytical Scale, 120g**
 Procedure: **DCN 500887**
 Accuracy: **±0.0005g**

Remarks: * Many factors may cause the unit to drift out of calibration before the recommended due date. Any reported error is the absolute value between the reference and the unit. Uncertainties include the effects of the unit.

Balance went into over range at max capacity. Adjusted balance to bring all points back into tolerance.

Standards Used

Std ID	Manufacturer	Model	Nomenclature	Due Date	Trace ID
256A	Rice Lake	W0133K	Mass Set,	05/30/2019	660578

Parameter

Measurement Data

Measurement Description	Range Unit	Reference	Min	Max	*Error	UUT	Uncertainty
Before							Accredited = ✓
Force							
	g	10.00000	9.9995	10.0005	0.0004	10.0004 g	5.7E-04 ✓
	g	30.00000	29.9995	30.0005	0.0004	30.0004 g	5.7E-04 ✓
	g	60.00000	59.9995	60.0005	0.0004	60.0004 g	5.7E-04 ✓
	g	90.00000	89.9995	90.0005	0.0005	90.0005 g	5.7E-04 ✓
	g	120.00000	119.9995	120.0005	120.0000	0.0000 g	5.7E-04 ✓
After							Accredited = ✓
	g	10.00000	9.9995	10.0005	0.0000	10.0000 g	5.7E-04 ✓
	g	30.00000	29.9995	30.0005	0.0001	29.9999 g	5.7E-04 ✓
	g	60.00000	59.9995	60.0005	0.0001	60.0001 g	5.7E-04 ✓
	g	90.00000	89.9995	90.0005	0.0002	89.9998 g	5.7E-04 ✓
	g	120.00000	119.9995	120.0005	0.0002	119.9998 g	5.7E-04 ✓

JJ Calibrations, Inc. certifies that this instrument has been calibrated in accordance with the JJ Calibrations Quality Assurance Manual with the stated procedure using standards that are traceable to the National Institute of Standards and Technology (NIST), or other National Measurement Institutes (NMI's), or by using natural physical constants, intrinsic standards or ratio calibration techniques. The quality system and this certificate are in compliance with ANSI/NCCL Z540-1-1994, ISO/IEC 17025-2005, ISO 10012-1, the ISO 9000 family and QS 9000. The expanded uncertainties of measurements for this calibration are based upon 95% (2 sigma) confidence limits. Unless otherwise stated, a test accuracy ratio (TAR) of 4:1, if achievable, is maintained. The results reported herein apply only to the calibration of the item described above. This report may not be reproduced, except in full, without prior written consent of JJ Calibrations, Inc.
 JJ Calibrations, Inc. quality system has been assessed and accredited to ISO/IEC 17025:2005.

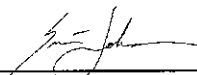
Reviewer 

3 Issued 08/09/2018 Rev # 15

Inspector 



Calibration complies with ISO/IEC 17025, ANSI/NCSL Z540-1, and 9001



Cert. No.: 6530-9263396

Traceable® Certificate of Calibration for Digital Barometer

Manufactured for and distributed by : Control Company "Drawer 58307,Houston,TX,77258,USA"

Instrument Identification:

Model: 6530,

S/N: 181062211

Manufacturer: Control Company

Standards/Equipment:

Description	Serial Number	Due Date	NIST Traceable Reference
Digital Barometer	D4540001	09 Oct 2018	1000415948
Digital Thermometer	130070752	02 Mar 2018	4000-8360837
Chilled Mirror Hygrometer	44654/2H3737	02 Nov 2019	15478
Climate Chamber	W613.0046		

Certificate Information:

Technician: 57

Procedure: CAL-31

Cal Date: 26 Feb 2018

Cal Due Date: 26 Feb 2020

Test Conditions: 54.9%RH 22.83°C 1023mBar

Calibration Data: (New Instrument)

Unit(s)	Nominal	As Found	In Tol	Nominal	As Left	In Tol	Min	Max	±U	TUR
%RH	N.A.	N.A.		51.21	52	Y	49	55	0.74	>4:1
°C	N.A.	N.A.		24.55	24.3	Y	24.15	24.96	0.051	>4:1
mb/hPa	N.A.	N.A.		1010.30	1010	Y	1007	1015	0.62	>4:1
mb/hPa	N.A.	N.A.		806.75	806	Y	803	811	0.62	>4:1
mb/hPa	N.A.	N.A.		908.50	908	Y	905	913	0.62	>4:1

This certificate indicates Traceability to standards provided by (NIST) National Institute of Standards and Technology and/or a National Standards Laboratory.

A Test Uncertainty Ratio of at least 4:1 is maintained unless otherwise stated and is calculated using the expanded measurement uncertainty. Uncertainty evaluation includes the instrument under test and is calculated in accordance with the ISO "Guide to the Expression of Uncertainty in Measurement : (GUM). The uncertainty represents an expanded uncertainty using a coverage factor k=2 to approximate a 95% confidence level. In tolerance conditions are based on test results falling within specified limits with no reduction by the uncertainty of the measurement. The results contained herein relate only to the item calibrated. This certificate shall not be reproduced except in full, without written approval of Control Company.

Nominal=Standard's Reading; As Left=Instrument's Reading; In Tol=In Tolerance; Min/Max=Acceptance Range; ± U=Expanded Measurement Uncertainty; TUR=Test Uncertainty Ratio; Accuracy=±(Max-Min)/2; Min=As Left Nominal(Rounded) - Tolerance; Max= As Left Nominal(Rounded) + Tolerance;

Nicol Rodriguez, Quality Manager

Aaron Judice, Technical Manager

Maintaining Accuracy:

In our opinion once calibrated your Digital Barometer should maintain its accuracy. There is no exact way to determine how long calibration will be maintained. Digital Barometer change little, if any at all, but can be affected by aging, temperature, shock, and contamination.

Recalibration:

For factory calibration and re-certification traceable to National Institute of Standards and Technology contact Control Company.

CONTROL COMPANY 12554 Galveston RD Suite B230 Webster TX USA 77598
Phone 281 482-1714 Fax 281 482-9448 sales@control3.com www.control3.com

Control Company is an ISO/IEC 17025:2005 Calibration Laboratory Accredited by (A2LA) American Association for Laboratory Accreditation, Certificate No. 1750.01.
Control Company is ISO 9001:2008 Quality Certified by DNV GL, Certificate No. CERT-01805-2006-AQ-HOU-RvA.
International Laboratory Accreditation Cooperation (ILAC) - Multilateral Recognition Arrangement (MRA).

3.3 - Example Calculations

Equations and Sample Calculations - ASTM E2779 & E2515

Manufacturer:	Hearth & Home
Model:	CB 1200I-C
Run:	1
Category:	Integrated

Equations used to calculate the parameters listed below are described in this appendix. Sample calculations are provided for each equation. The raw data and printout results from a sample run are also provided for comparison to the sample calculations.

M_{Bdb} - Weight of test fuel burned during test run, dry basis, kg

M_{BSidb} - Weight of test fuel burned during test run segment i , dry basis, kg

BR - Average dry burn rate over full integrated test run, kg/hr

BR_{Si} - Average dry burn rate over test run segment i , kg/hr

V_s - Average gas velocity in the dilution tunnel, ft/sec

Q_{sd} - Average gas flow rate in dilution tunnel, dscf/hr

$V_{m(std)}$ - Volume of Gas Sampled Corrected to Dry Standard Conditions, dscf

m_n - Total Particulate Matter Collected, mg

C_s - Concentration of particulate matter in tunnel gas, dry basis, corrected to standard conditions, g/dscf

E_T - Total Particulate Emissions, g

PR - Proportional Rate Variation

PM_R - Average particulate emissions for full integrated test run, g/hr

PM_F - Average particulate emission factor for full integrated test run, g/dry kg of fuel burned

Equations and Sample Calculations - ASTM E2779 & E2515

M_{Bdb} - Weight of test fuel burned during test run, dry basis, kg

ASTM E2779 equation (1)

$$M_{Bdb} = (M_{Swb} - M_{Ewb})(100/(100 + FM))$$

Where,

- FM = average fuel moisture of test fuel, % dry basis
- M_{Swb} = weight of test fuel in hopper at start of test run, wet basis, kg
- M_{Ewb} = weight of test fuel in hopper at end of test run, wet basis, kg

Sample Calculation:

6.27 %

$$M_{Swb} = 34.1 \text{ lbs}$$

$$M_{Ewb} = 18.3 \text{ lbs}$$

0.4536 = Conversion factor from lbs to kg

$$M_{Bdb} = [(34.1 \times 0.4536) - (18.3 \times 0.4536)] (100/(100 + 6.27))$$

$$M_{Bdb} = 6.74 \text{ kg}$$

Equations and Sample Calculations - ASTM E2779 & E2515

M_{BSidb} - Weight of test fuel burned during test run segment i , dry basis, kg

ASTM E2779 equation (2)

$$M_{BSidb} = (M_{S_{Siwb}} - M_{E_{Siwb}})(100 / (100 + FM))$$

Where,

$M_{S_{Siwb}}$ = weight of test fuel in hopper at start of test run segment i , wet basis, kg

$M_{E_{Siwb}}$ = weight of test fuel in hopper at end of test run segment i , wet basis, kg

Sample Calculation (from medium burn rate segment):

$$FM = 6.27 \%$$

$$M_{S_{Siwb}} = 28.4 \text{ lbs}$$

$$M_{E_{Siwb}} = 24.3 \text{ lbs}$$

0.4536 = Conversion factor from lbs to kg

$$M_{BSidb} = [(28.4 \times 0.4536) - (24.3 \times 0.4536)] (100 / (100 + 6.27))$$

$$M_{BSidb} = 1.8 \text{ kg}$$

Equations and Sample Calculations - ASTM E2779 & E2515

BR - Average dry burn rate over full integrated test run, kg/hr

ASTM E2779 equation (3)

$$BR = \frac{60 M_{Bdb}}{\theta}$$

Where,

θ = Total length of full intergrated test run, min

Sample Calculation:

$$M_{Bdb} = 6.74 \quad \text{kg}$$

$$\theta = 360 \quad \text{min}$$

$$BR = \frac{60 \times 6.74}{360}$$

$$BR = 1.12 \quad \text{kg/hr}$$

Equations and Sample Calculations - ASTM E2779 & E2515

BR_{Si} - Average dry burn rate over test run segment i , kg/hr

ASTM E2779 equation (4)

$$BR_{Si} = \frac{60 M_{BSidb}}{\theta_{Si}}$$

Where,

$$\theta_{Si} = \text{Total length of test run segment } i, \text{ min}$$

Sample Calculation (from medium burn rate segment):

$$M_{BSidb} = 1.75 \text{ kg}$$

$$\theta = 120 \text{ min}$$

$$BR = \frac{60 \times 1.75}{120}$$

$$BR = 0.88 \text{ kg/hr}$$

Equations and Sample Calculations - ASTM E2779 & E2515

V_s - Average gas velocity in the dilution tunnel, ft/sec

ASTM E2515 equations (9)

$$V_s = F_p \times K_p \times C_p \times (\sqrt{\Delta P})_{avg} \times \sqrt{\frac{T_s}{P_s \times M_s}}$$

Where:

- F_p = djustment factor for center of tunnel pitot tube placement, $F_p = \frac{V_{strav}}{V_{scent}}$, ASTM E2515 Equation (1)
- V_{scent} = Dilution tunnel velocity calculated after the multi-point pitot traverse at the center, ft/sec
- V_{strav} = Dilution tunnel velocity calculated after the multi-point pitot traverse, ft/sec
- k_p = Pitot tube constant, 85.49
- C_p = Pitot tube coefficient: 0.99, unitless
- ΔP^* = Velocity pressure in the dilution tunnel, in H₂O
- T_s = Absolute average gas temperature in the dilution tunnel, °R; (°R = °F + 460)
- P_s = Absolute average gas static pressure in diluion tunnel, = $P_{bar} + P_g$, in Hg
- P_{bar} = Barometric pressure at test site, in. Hg
- P_g = Static pressure of tunnel, in. H₂O; (in Hg = in H₂O/13.6)
- M_s = **The dilution tunnel wet molecular weight; $M_s = 28.78$ assuming a dry weight of 29 lb/lb-mole

Sample calculation:

$$F_p = \frac{14.23}{16.08} = 0.885$$

$$V_s = 0.885 \times 85.49 \times 0.99 \times 0.234 \times \left(\frac{99.4 + 460}{30.02 + \frac{-0.22}{13.6}} \right)^{1/2} \times 28.78$$

$$V_s = 14.12 \text{ ft/s}$$

*The ASTM test standard mistakenly has the square root of the average delta p instead of the average of the square root of delta p. The current EPA Method 2 is also incorrect. This was verified by Mike Toney at EPA.

**The ASTM test standard mistakenly identifies M_s as the dry molecular weight. It should be the wet molecular weight as indicated in EPA Method 2.

Equations and Sample Calculations - ASTM E2779 & E2515

Q_{sd} - Average gas flow rate in dilution tunnel, dscf/hr

ASTM E2515 equation (3)

$$Q_{sd} = 3600 \times (1 - B_{ws}) \times v_s \times A \times \frac{T_{std}}{T_s} \times \frac{P_s}{P_{std}}$$

Where:

3600	=	Conversion from seconds to hours (ASTM method uses 60 to convert in minutes)
B_{ws}	=	Water vapor in gas stream, proportion by volume; assume 2%
A	=	Cross sectional area of dilution tunnel, ft ²
T_{std}	=	Standard absolute temperature, 528 °R
P_s	=	Absolute average gas static pressure in dilution tunnel, = $P_{bar} + P_g$, in Hg
T_s	=	Absolute average gas temperature in the dilution tunnel, °R; (°R = °F + 460)
P_{std}	=	Standard absolute pressure, 29.92 in Hg

Sample calculation:

$$Q_{sd} = 3600 \times (1 - 0.02) \times 14.12 \times 0.1963 \times \frac{528}{99.4 + 460} \times \frac{30.02 + \frac{-0.22}{13.6}}{29.92}$$

$$Q_{sd} = 9254.3 \text{ dscf/hr}$$

Equations and Sample Calculations - ASTM E2779 & E2515

$V_{m(std)}$ - Volume of Gas Sampled Corrected to Dry Standard Conditions, dscf

ASTM E2515 equation (6)

$$V_{m(std)} = K_1 \times V_m \times Y \times \frac{P_{bar} + \left(\frac{\Delta H}{13.6} \right)}{T_m}$$

Where:

- K_1 = 17.64 °R/in. Hg
- V_m = Volume of gas sample measured at the dry gas meter, dcf
- Y = Dry gas meter calibration factor, dimensionless
- P_{bar} = Barometric pressure at the testing site, in. Hg
- ΔH = Average pressure differential across the orifice meter, in. H₂O
- T_m = Absolute average dry gas meter temperature, °R

Sample Calculation:

Using equation for Train 1:

$$V_{m(std)} = 17.64 \times 58.023 \times 0.986 \times \frac{\left(30.02 + \frac{1.34}{13.6} \right)}{\left(78.7 + 460 \right)}$$

$$V_{m(std)} = 56.413 \text{ dscf}$$

Using equation for Train 2:

$$V_{m(std)} = 17.64 \times 59.019 \times 0.985 \times \frac{\left(30.02 + \frac{1.09}{13.6} \right)}{\left(79.2 + 460 \right)}$$

$$V_{m(std)} = 57.233 \text{ dscf}$$

Using equation for ambient train:

$$V_{m(std)} = 17.64 \times 0.00 \times 0 \times \frac{\left(30.02 + \frac{0.00}{13.6} \right)}{\left(69.1 + 460 \right)}$$

$$V_{m(std)} = 0.000 \text{ dscf}$$

Equations and Sample Calculations - ASTM E2779 & E2515

m_n - Total Particulate Matter Collected, mg

ASTM E2515 Equation (12)

$$m_n = m_p + m_f + m_g$$

Where:

m_p = mass of particulate matter from probe, mg

m_f = mass of particulate matter from filters, mg

m_g = mass of particulate matter from filter seals, mg

Sample Calculation:

Using equation for Train 1 (first hour):

$$m_n = 0.0 + 1.0 + 0.0$$

$$m_n = 1.0 \text{ mg}$$

Using equation for Train 1 (remainder):

$$m_n = 0.0 + 3.2 + 0.5$$

$$m_n = 3.7 \text{ mg}$$

Train 1 Aggregate = **4.7 mg**

Using equation for Train 2:

$$m_n = 0.0 + 3.6 + 1.3$$

$$m_n = **4.9** \text{ mg}$$

Equations and Sample Calculations - ASTM E2779 & E2515

C_s - Concentration of particulate matter in tunnel gas, dry basis, corrected to standard conditions, g/dscf

ASTM E2515 equation (13)

$$C_s = K_2 \times \frac{m_n}{V_{m(\text{std})}}$$

Where:

K_2 = Constant, 0.001 g/mg

m_n = Total mass of particulate matter collected in the sampling train, mg

$V_{m(\text{std})}$ = Volume of gas sampled corrected to dry standard conditions, dscf

Sample calculation:

For Train 1:

$$C_s = 0.001 \times \frac{4.7}{56.41}$$

$$C_s = 8.33\text{E-}05 \text{ g/dscf}$$

For Train 2

$$C_s = 0.001 \times \frac{4.9}{57.23}$$

$$C_s = 8.56\text{E-}05 \text{ g/dscf}$$

For Ambient Train

$$C_r = 0.001 \times \frac{0.0}{0.00}$$

$$C_r = 0.000000 \text{ g/dscf}$$

Equations and Sample Calculations - ASTM E2779 & E2515

E_T - Total Particulate Emissions, g

ASTM E2515 equation (15)

$$E_T = (c_s - c_r) \times Q_{std} \times \theta$$

Where:

- C_s = Concentration of particulate matter in tunnel gas, g/dscf
- C_r = Concentration particulate matter room air, g/dscf
- Q_{std} = Average dilution tunnel gas flow rate, dscf/hr
- θ = Total time of test run, minutes

Sample calculation:

For Train 1

$$E_T = (\underline{0.000083} - 0.000000) \times \underline{9254.3} \times \underline{360} / 60$$
$$E_T = \underline{4.63} \text{ g}$$

For Train 2

$$E_T = (\underline{0.000086} - 0.000000) \times \underline{9254.3} \times \underline{360} / 60$$
$$E_T = \underline{4.75} \text{ g}$$

Average

$$E = \underline{4.69} \text{ g}$$

Total emission values shall not differ by more than 7.5% from the total average emissions

$$7.5\% \text{ of the average} = \underline{0.35}$$

$$\text{Train 1 difference} = \underline{0.06}$$

$$\text{Train 2 difference} = \underline{0.06}$$

Equations and Sample Calculations - ASTM E2779 & E2515

PR - Proportional Rate Variation

ASTM E2515 equation (16)

$$PR = \left[\frac{\theta \times V_{mi} \times V_s \times T_m \times T_{si}}{\theta_i \times V_m \times V_{si} \times T_{mi} \times T_s} \right] \times 100$$

Where:

- θ = Total sampling time, min
- θ_i = Length of recording interval, min
- V_{mi} = Volume of gas sample measured by the dry gas meter during the "ith" time interval, dcf
- V_m = Volume of gas sample as measured by dry gas meter, dcf
- V_{si} = Average gas velocity in the dilution tunnel during the "ith" time interval, ft/sec
- V_s = Average gas velocity in the dilution tunnel, ft/sec
- T_{mi} = Absolute average dry gas meter temperature during the "ith" time interval, °R
- T_m = Absolute average dry gas meter temperature, °R
- T_{si} = Absolute average gas temperature in the dilution tunnel during the "ith" time interval, °R
- T_s = Absolute average gas temperature in the dilution tunnel, °R

Sample calculation (for the first 1 minute interval of Train 1):

$$PR = \left(\frac{360 \times 0.149 \times 14.12 \times (118.0 + 460) \times (78.7 + 460)}{1 \times 58.023 \times 14.24 \times (99.4 + 460) \times (70.0 + 460)} \right) \times 100$$

$$PR = \underline{96} \%$$

Equations and Sample Calculations - ASTM E2779 & E2515

PM_R - Average particulate emissions for full integrated test run, g/hr

ASTM E2779 equation (5)

$$PM_R = 60 (E_T / \theta)$$

Where,

E_T = Total particulate emissions, grams

θ = Total length of full integrated test run, min

Sample Calculation:

$$E_T \text{ (Dual train average)} = 4.69 \text{ g}$$

$$\theta = 360 \text{ min}$$

$$PM_R = 60 \times (4.69 / 360)$$

$$PM_R = 0.78 \text{ g/hr}$$

Equations and Sample Calculations - ASTM E2779 & E2515

PM_F - Average particulate emission factor for full integrated test run, g/dry kg of fuel burned

ASTM E2779 equation (6)

$$PM_F = E_T / M_{Bdb}$$

Where,

E_T = Total particulate emissions, grams

M_{Bdb} = Weight of test fuel burned during test run, dry basis, kg

Sample Calculation:

$$E_T \text{ (Dual train average)} = 4.69 \text{ g}$$

$$M_{Bdb} = 6.74 \text{ kg}$$

$$PM_F = (4.69 / 6.74)$$

$$PM_F = 0.70 \text{ g/kg}$$

Appendix A – Labeling & Owner’s Manual



CAUTION: HOT WHILE IN OPERATION DO NOT TOUCH. KEEP CHILDREN, CLOTHING AND FURNITURE AWAY. CONTACT MAY CAUSE SKIN BURNS. SEE NAMEPLATE AND INSTRUCTIONS. Operate this unit with fuel hopper lid closed. Failure to do so may result in emissions products' combustion from the hopper under certain conditions. Maintain hopper seal in good condition. Do not over fill the hopper.

ATTENTION: CHAUD LORS DE L'OPÉRATION. NE PAS TOUCHER. GARDEZ LES ENFANTS ET LES VÊTEMENTS LOIN DE L'ESPACE DÉSIGNÉ DE L'INSTALLATION. LE CONTACT PEUT CAUSER DES BRÛLURES À LA PEAU. VOIR L'ÉTIQUETTE ET LES INSTRUCTIONS. Opérez cet appareil avec le couvercle de la trémie fermé. Le défaut de ne pas suivre les instructions peut résulter, sous certaines conditions, en une combustion des émissions des produits venant de la trémie. Ne pas remplir la trémie trop pleine.



Report / Rapport
#061-S-13-2
0061PNO13E

Serial Number is located below on the hopper body. / Numéro de série se trouve au-dessous de la trémie corps.

QUADRA-FIRE

CB12001-C



Manufactured by / Fabriqué par:



352 Mountain House Road
Halifax, PA 17032

Listed Solid Fuel Room Heater/Pellet Type Insert. Also suitable for Mobile Home Installation. This appliance has been tested and listed for use in Manufactured Homes in accordance with OAR 814-23-9000 through 814-23-909. / Appareil de chauffage inséré de combustible solide/de type de boulettes. Accepté dans l'installation dans les maisons mobiles. Cet appareil a été testé et enregistré pour l'usage dans les Maisons Mobiles en accord avec OAR 814-23-9000 jusqu'à 814-23-909.

Tested to: ASTM E1509-95, UL127, ULC S628-93, and ULC S610-M87 Room Heating Pellet Burning Type, 40 CFR § 60.534(h), (UM) 84-HUD FOR USE ONLY WITH PELLETIZED WOOD. / **Testé à:** ASTM E1509-95, UL127, ULC S628-93 et ULC S610-M87 Room Heating Pellet Burning Type, APFI, (UM) 84-HUD À UTILISER UNIQUEMENT AVEC DU BOIS GRANULÉ.

Input Rating: 48,500 Btu's/hr. / **Puissance de Rendement :** 48,500 Btu's/hr.

Electrical Rating: 115 VAC, 60 Hz, Start 4.1 Amps, Run 1.1 AMPS. Route power cord away from unit. Do not route cord under or in front of appliance. / **Puissance Électrique :** 115 VAC, 60 Hz, Début 4.1 Amps, Courir 1.1 Amps, Éloignez le fil électrique de l'appareil. Ne pas faire passer le fil électrique au dessus ou en dessous de l'appareil.

DANGER: Risk of electrical shock. Disconnect power supply before servicing. Replace glass only with 5mm ceramic available from your dealer. To start, set thermostat above room temperature, the stove will light automatically. To shutdown, set thermostat to below room temperature. For further instruction refer to owner's manual. Keep viewing and ash removal doors tightly closed during operation. / **DANGER: Il y a risque de décharge électrique.** Déconnectez le fil électrique de la prise de contact avant le service.

Remplacez la vitre seulement avec une vitre céramique de 5 mm disponible chez votre fournisseur. Pour allumer, monter la température du thermostat au dessus de la température de la pièce, le poêle s'allumera automatiquement. Pour éteindre, descendre la température du thermostat en dessous de la température de la pièce. Pour des instructions supplémentaires, référez vous au manuel du propriétaire. Gardez la porte d'ouverture et la porte des cendres fermées hermétiquement durant l'opération.

PREVENT HOUSE FIRES / PRÉVENTION DES FEUX DE MAISON

Install and use only in accordance with manufacturer's installation and operating instructions. Contact local building or fire officials about restrictions and inspection in your area. / Installez et utilisez en accord avec les instructions d'installation et d'opération du fabricant. Contactez le bureau de la construction ou le bureau des incendies au sujet des restrictions et des inspections d'installation dans votre voisinage. Ne pas obstruez l'espace en dessous de l'appareil.

WARNING - FOR MOBILE HOMES: Do not install appliance in a sleeping room. An outside combustion air inlet must be provided. The structural integrity of the mobile home floor, ceiling and walls must be maintained. Refer to manufacturer's instructions and local codes for precautions required for passing chimney through a combustible wall or ceiling. Inspect and clean vent system frequently in accordance with manufacturer's instructions. / **AVIS - POUR LES MAISONS MOBILES :** Ne pas installer dans une chambre à coucher. Un tuyau extérieur de combustion d'air doit être installé et ne doit pas être obstrué lorsque l'appareil est en usage. La structure intégrale du plancher, du plafond et des murs de la maison mobile doit être maintenue intacte. Référez vous aux instructions du fabricant et des codes locaux pour les précautions requises pour passer une cheminée à travers un mur ou un plafond combustibles, et les compensations maximums.

DO NOT CONNECT THIS UNIT TO A CHIMNEY SERVING ANOTHER APPLIANCE. Use a 3" or 4" diameter type "L" or "PL" venting system. / **NE PAS CONNECTER CET APPAREIL À UNE CHEMINÉE SERVANT UN AUTRE APPAREIL.** Utilisez système de ventilation "L" ou "P" diamètre 76mm ou 102mm.

MINIMUM CLEARANCES TO COMBUSTIBLE MATERIALS

AS A BUILT-IN UNIT WITH REAR SHROUD

A	Top of Inside Shroud	Rear Vent	0" (0mm)
		Top Vent	3" (76mm)
B	Sides of Inside Shroud	Top or Rear	0" (0mm)
C	Back of Inside Shroud)	Rear Vent	0" (0mm)
		Top Vent)	2-1/2" (64mm)
D	Vent Pipe to Combustible	Rear Vent	3" (76mm)
E	From Panel Edge		0" (0mm)

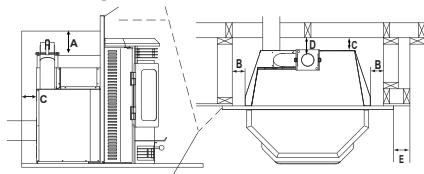

0" (0mm) Clearance To Exposed Section and Face Trim

HEARTH PROTECTION

*Zero clearance installation requires non-combustible hearth material with an R value of 3.0 or more ("k" value of .58) or a 1" (25mm) air space between insert base and hearth. Floor Protection Part 811-0730 is available from your dealer for the section under the insert body only.

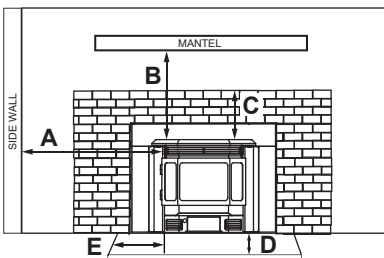

MASONRY OR *ZERO CLEARANCE MINIMUM CLEARANCES TO COMBUSTIBLE / MAÇONNERIE OU ZÉRO DISTANCE FOYER DISTANCES MINIMALES À TOUT MATÉRIEL COMBUSTIBLE.

A	Louvers to combustible wall / Lucarne au mur combustible	6" (152mm)
B	Insert top to mantel / Dessus de l'insert à la tablette de cheminée	12" (305mm)
C	Front Facing / Revêtement facial	3" (76mm)
D*	Hearth Extension - Front / Protection de sol - frontal	6" (152mm)
E*	Hearth Extension - Side / Protection ole sol - côté	8" (203mm)

*See hearth protection note above. / *Voir les notes sur la protection ole sol ci-dessus.

U.S. ENVIRONMENTAL PROTECTION AGENCY

Certified to comply with 2020 particulate emission standards at 0.78 g/hr EPA method 28R and ASTM 2779 using premium wood pellets. This wood heater needs periodic inspection and repair for proper operation. Consult the owner's manual for further information. It is against federal regulations to operate this wood heater in a manner inconsistent with the operating instructions in the owner's manual.



DO NOT REMOVE THIS LABEL / NE PAS ENLEVER L'ÉTIQUETTE

MADE IN TAIWAN / FAIT AUX TAIWAN

Serial No. / N° de série :



7027-803D

Owner's Manual

Operation & Care

INSTALLER: Leave this manual with party responsible for use and operation.

OWNER: Retain this manual for future reference.

Contact your dealer with questions on installation, operation, or service.

NOTICE: DO NOT DISCARD THIS MANUAL

QUADRA-FIRE®

**CLASSIC BAY 1200 PELLET
APPLIANCE
MODEL NUMBER:
CB1200-C**

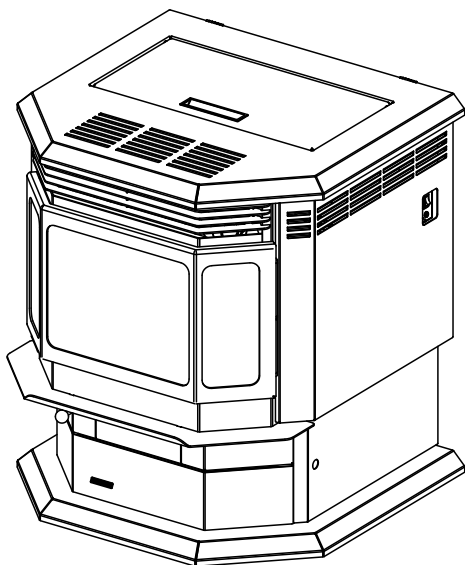

CAUTION

Tested and approved for wood pellet fuel only. Burning of any other type of fuel voids your warranty.

Installation and service of this appliance should be performed by qualified personnel. Hearth & Home Technologies recommends HHT Factory Trained or NFI certified professionals.



WARNING



If the information in these instructions is not followed exactly, a fire may result causing property damage, personal injury, or death.

- Do not store or use gasoline or other flammable vapors and liquids in the vicinity of this or any other appliance.
- Do not over fire - If appliance or chimney connector glows, you are over firing. Over firing will void your warranty.
- Comply with all minimum clearances to combustibles as specified.

Failure to comply may cause house fire.



WARNING



HOT SURFACES!

Glass and other surfaces are hot during operation AND cool down.

Hot glass will cause burns.

- Do not touch glass until it is cooled.
- NEVER allow children to touch glass.
- Keep children away.
- CAREFULLY SUPERVISE children in same room as fireplace.
- Alert children and adults to hazards of high temperatures.
- High temperatures may ignite clothing or other flammable materials.
- Keep clothing, furniture, draperies and other flammable materials away.



CAUTION

Check building codes prior to installation.

- Installation MUST comply with local, regional, state and national codes and regulations.
- Consult local building, fire officials or authorities having jurisdiction about restrictions, installation inspection, and permits.

NOTE: To obtain a French translation of this manual, please contact your dealer or visit www.quadrafire.com

REMARQUE : Pour obtenir une traduction française de ce manuel, s'il vous plaît contacter votre revendeur ou visitez www.quadrafire.com

Congratulations

and Welcome to the Quadra-Fire Family!

NOTE: Clearances may only be reduced by means approved by the regulatory authority having jurisdiction.

A. Sample of Serial Number / Safety Label

LOCATION: Back of Appliance

Test Lab & Report No.

Report / Rapport
061-S-21-4
0061PS013E

CB1200-C

Serial No. /
N° de série: **US**

BARCODE LABEL

Listed Solid Fuel Room Heater/Pellet Type. Also suitable for Mobile Home Installation. This appliance has been tested and listed for use in Manufactured Homes in accordance with OAR 814-23-9000 through 814-23-909.

Appareil de chauffage de combustible solide/de type de boulettes. Accepté dans l'installation dans les maisons mobiles. Cet appareil a été testé et enregistré pour l'usage dans les Maisons Mobiles en accord avec OAR 814-23-9000 jusqu'à 814-23-909.

PREVENT HOUSE FIRES / PRÉVENTION DES FEUX DE MAISON

Install and use only in accordance with manufacturer's installation and operating instructions. Contact local building or fire officials about restrictions and inspection in your area.

WARNING - FOR MOBILE HOMES: Do not install appliance in a sleeping room. An outside combustion air inlet must be provided. The structural integrity of the mobile home floor, ceiling and walls must be maintained. Refer to manufacturer's instructions and local codes for precautions required for passing chimney through a combustible wall or ceiling. Inspect and clean vent system frequently in accordance with manufacturer's instructions. **DO NOT CONNECT THIS UNIT TO A CHIMNEY SERVING ANOTHER APPLIANCE.** Use a 3" or 4" diameter type "L" or "PL" venting system.

Installez et utilisez en accord avec les instructions d'installation et d'opération du fabricant. Contactez le bureau de la construction ou le bureau des incendies au sujet des restrictions et des inspections d'installation dans votre voisinage. Ne pas obstruer l'espace en dessous de l'appareil.

AVIS - Pour Les Maisons Mobiles: Ne pas installer dans une chambre à coucher. Un tuyau extérieur de combustion d'air doit être installé et ne doit pas être obstrué lorsque l'appareil est en usage. La structure intégrale du plancher, du plafond et des murs de la maison mobile doit être maintenue intacte. Référez vous aux instructions du fabricant et des codes locaux pour les précautions requises pour passer une cheminée à travers un mur ou un plafond combustibles, et les compensations maximums. Inspectez et nettoyez la cheminée fréquemment. Ne pas connecter cet appareil à une cheminée servant à un autre appareil. Utilisez système de ventilation "L" ou "PL" diamètre 76mm ou 102mm.

Conforms to ASTM Std E1509-12. Certified to ULC S627-00. Room Heating Pellet Burning Type, (UM) 84-HUD FOR USE ONLY WITH PELLETIZED WOOD FUEL. Do not use any other type of fuel.

Conforme à la norme ASTM E1509-12 Std. Certifié à la norme ULC S627-00. Room Heating Pellet Burning Type, (UM) 84-HUD POUR USAGE AVEC LES BOULETTES DE BOIS. N'utiliser aucun autre genre de combustible.

Input Rating: 41,120 Btu's/hr. Electrical Rating: 115 VAC, 60 Hz, Start 3.75 Amps, Run 1.88 Amps. Route power cord away from unit. Do not route cord under or in front of appliance. Do not obstruct the space beneath the heater.

Puissance de Rendement : 41,120 Btu's/hr. Puissance Électrique : 115 VAC, 60 Hz, Début 3.75 Amps, Courir 1.88 Amps, Éloignez le fil électrique de l'appareil. Ne pas faire passer le fil électrique au dessus ou en dessous de l'appareil. Ne pas bloquer l'espace en dessous de l'appareil.

DANGER: Risk of electrical shock. Disconnect power supply before servicing. Replace glass only with 6mm ceramic. To start, turn dial control to desired setting and set thermostat above room temperature, the stove will light automatically. To shutdown, turn dial control to OFF or set thermostat below room temperature. For further instruction refer to owner's manual. Keep viewing doors tightly closed during operation. Keep viewing and ash removal doors tightly closed during operation.

DANGER: Il y a risque de décharge électrique. Déconnectez le fil électrique de la prise de contact avant le service. Remplacez la vitre seulement avec une vitre céramique de 6 mm disponible chez votre fournisseur. Pour commencer, tournez la molette de réglage à la température désirée et réglez le thermostat au-dessus de la température ambiante, le poêle s'allumera automatiquement. Pour éteindre, tournez la molette de réglage sur OFF ou réglez le thermostat dessous de la température ambiante. Pour de plus amples instructions sur les opérations, référez vous au manuel du propriétaire. Gardez la porte d'ouverture et la porte de nettoyage fermées pendant l'opération.

MINIMUM CLEARANCES TO COMBUSTIBLE MATERIALS /
ÉCARTS MINIMUMS DES MATÉRIEAUX :

A	Back Wall to Appliance / Mur Arrière	2 in [51 mm]
B	Side Wall to Appliance Top/ Mur De Côté	6 in [152 mm]
C	Flue Pipe to Back Wall / Le Tuyau de fumée à l'Arrière de la Paroi	3 in [76 mm]
D	Side Wall to Corner of Appliance/ Mur De Côté	2 in [51 mm]

FLOOR PROTECTION / PROTECTION DU SOL

<p>USA</p> <p>G = 2 in H* = 2 in I = 6 in</p> <p>CANADA</p> <p>G = 51 mm H* = 51 mm I = 152 mm</p>	<p>Floor protector must be non-combustible material, extending beneath heater and to the front/sides/rear as indicated. Measure front distance (I) from the surface of the glass door.</p> <p>Le poêle doit être placé sur une assise non combustible s'étendant tout autour de lui, comme les schémas l'indiquent. Mesurez la distance du devant (I) de la surface de la porte vitrée.</p>	<p>*Non-combustible floor protection must extend 2 inches (51mm) beneath the flue pipe when installed with horizontal venting or under the Top Vent Adapter with vertical installation. RECOMMENDED IN USA; REQUIRED IN CANADA.</p> <p>*Un protecteur incombustible de plancher doit s'étendre 2 inches (51mm) sous le conduit de cheminée pour une installation de ventilation horizontale ou sous un adaptateur de ventilation de dessus pour une installation verticale. RECOMMANDÉ AUX ÉTATS-UNIS; NÉCESSAIRE AU CANADA.</p>
--	---	--

Manufactured by /
Fabriqué par :

U.S. ENVIRONMENTAL PROTECTION AGENCY

Certified to comply with 2020 particulate emission standards at 1.0 g/hr EPA method 28R and ASTM 2779 using premium wood pellets. This wood heater needs periodic inspection and repair for proper operation. Consult the owner's manual for further information. It is against federal regulations to operate this wood heater in a manner inconsistent with the operating instructions in the owner's manual.

2023 2024 2025 JAN FEB MAR APR MAY JUN JUL AUG SEP OCT NOV DEC

DO NOT REMOVE THIS LABEL / NE PAS ENLEVER L'ÉTIQUETTE

Made in Taiwan / Fabriqué en Taiwan

7027-800C

Mfg. Date



Safety Alert Key:

- **DANGER!** Indicates a hazardous situation which, if not avoided will result in death or serious injury.
- **WARNING!** Indicates a hazardous situation which, if not avoided could result in death or serious injury.
- **CAUTION!** Indicates a hazardous situation which, if not avoided, could result in minor or moderate injury.
- **NOTICE:** Indicates practices which may cause damage to the appliance or to property.

TABLE OF CONTENTS

<p>A. Sample of Serial Number / Safety Label 2</p> <p>B. Warranty Policy 4</p> <p>1 Listing and Code Approvals</p> <p>A. Appliance Safety Certification 6</p> <p>B. Appliance Emissions Certification 6</p> <p>→ C. BTU & Efficiency Specifications. 6</p> <p>D. Glass Specifications. 7</p> <p>E. Electrical Rating 7</p> <p>F. Mobile Home Approved 7</p> <p>G. Sleeping Room 7</p> <p>H. California - Prop65. 7</p> <p>2 Operating Instructions</p> <p>A. Fire Safety 8</p> <p>B. Non-Combustible Materials 8</p> <p>C. Combustible Materials 8</p> <p>D. Fuel Material and Fuel Storage 8</p> <p>E. Before Your First Fire. 9</p> <p>F. Filling the Hopper 9</p> <p>G. General Operating Information 10</p> <p>H. Starting Your First Fire. 10</p> <p>I. Fire Characteristics 10</p> <p>J. Feed Rate Adjustment Instructions. 11</p> <p>K. Ignition Cycles 11</p> <p>L. Restarting the Appliance. 11</p> <p>M. Clear Space. 12</p> <p>N. Thermostat Controls 12</p> <p>O. Thermostat Setup Options. 13</p> <p>P. Thermostat Operation Instructions 13</p> <p>Q. Thermostat Temperature Programs. 14</p> <p>R. Thermostat Other Features 14</p> <p>S. Thermostat Battery Replacement 15</p> <p>T. Frequently Asked Questions. 16</p>	<p>3 Maintenance and Service</p> <p>A. Proper Shutdown Procedure 17</p> <p>B. Quick Reference Maintenance Chart. 17</p> <p>C. General Maintenance and Cleaning 18</p> <p>D. Soot or Creosote Fire. 22</p> <p>E. High Ash Fuel Content Maintenance 22</p> <p>4 Troubleshooting Guide 23</p> <p>5 Service Parts Replacement</p> <p>A. Blowers 25</p> <p>B. Baffles 26</p> <p>C. Igniter. 26</p> <p>D. Glass 27</p> <p>6 Reference Materials</p> <p>A. Component Functions 28</p> <p>B. Component Locations 30</p> <p>C. Service and Maintenance Log 31</p> <p>D. Service Parts List. 34</p>
---	---

→ = Contains updated information

B. Warranty Policy

Hearth & Home Technologies LLC LIMITED LIFETIME WARRANTY

Hearth & Home Technologies LLC (“HHT”) extends the following warranty for HHT gas, wood, pellet and electric hearth appliances (each a “Product” and collectively, the “Product(s)”) and certain component parts set forth in the table below (“Component Part(s)”) that are purchased from a HHT authorized dealer or distributor.

WARRANTY COVERAGE:

HHT warrants that the Products and their Component Parts will be free from defects in materials and workmanship for the applicable period of Warranty coverage set forth in the table below (“Warranty Period”). If a Product or Component Parts are found to be defective in materials or workmanship during the applicable Warranty Period, HHT will, at its option, repair the applicable Component Part(s), replace the applicable Component Part(s), or refund the purchase price of the applicable Product(s). The maximum amount recoverable under this Warranty is limited to the purchase price of the Product. This Warranty is transferable from the original purchaser to subsequent owners, but the Warranty Period will not be extended in duration or expanded in coverage for any such transfer. This Warranty is subject to conditions, exclusions, and limitations as described below.

WARRANTY PERIOD:

Warranty coverage begins at the date of installation. In the case of new home constructions, Warranty coverage begins on the date of first occupancy of the dwelling or six months after the sale of the Product(s) by an independent, authorized HHT dealer or distributor, whichever occurs earlier. However, the Warranty coverage shall commence no later than 24 months following the date of Product shipment from HHT, regardless of the installation or occupancy date.

The term “Lifetime” in the table below is defined as: 20 years from the beginning date of warranty coverage for gas appliances, and 10 years from the beginning date of warranty coverage for wood and pellet appliances. These time periods reflect the minimum expected useful lives of the designated Component Parts under normal operating conditions.

Warranty Period		HHT Manufactured Appliances and Venting					
Component Parts	Labor	Gas	Pellet	Wood	Electric	Venting	Component Parts Covered by this Warranty
1 Year		X	X	X		X	All parts including handles, external enameled components and other material except as covered by Warranty Conditions, Warranty Exclusions, and Warranty Limitations listed
2 Years					X		All parts except as covered by Warranty Conditions, Warranty Exclusions, and Warranty Limitations listed
2 years			X	X			Igniters, Auger Motors, Electronic Components, and Glass
		X					Electrical components limited to modules, remotes/wall switches, valves, pilots, blowers, junction boxes, wire harnesses, transformers and lights (excluding light bulbs)
		X		X			Molded Refractory Panels, Glass Liners
3 years			X				Firepots, burnpots, mechanical feeders/auger assemblies
5 years	1 year	X					Vent Free Burners, Vent Free Logs
			X	X			Castings, Medallions and Baffles
6 years	3 years			X			Catalysts
7 years	3 years		X	X			Manifold tubes, HHT Chimney and Terminations
10 years	1 year	X					Burners, logs and refractory
Limited Lifetime	3 years	X	X	X			Firebox and heat exchanger, FlexBurn® System (engine, inner cover, access cover and fireback)
1 Year	None	X	X	X	X	X	All purchased replacement parts

WARRANTY CONDITIONS:

- Because HHT cannot control the quality of any Products sold by unauthorized sellers, this Warranty only covers Products that are purchased through an HHT authorized dealer or distributor unless otherwise prohibited by law; a list of HHT authorized dealers is available on the HHT branded websites.
- This Warranty is only valid while the applicable Product remains at the site of original installation.
- This Warranty is only valid in the country in which the HHT authorized dealer or distributor that sold the applicable Product is authorized to sell applicable Product.
- Contact your installing distributor or dealer for Warranty service. If the installing dealer or distributor is unable to provide necessary parts, contact the nearest HHT authorized dealer or supplier. Additional service fees may apply if you are seeking Warranty service from a dealer other than the dealer from whom you originally purchased the applicable Product.
- No HHT consumer should bear cost of warranty service or costs incurred while servicing warranty claims (i.e., travel, gas, or mileage) when the service is performed within the terms of this Warranty. Check with your dealer or distributor in advance for any costs to you when arranging a warranty call. Travel and shipping charges for parts are not covered by this Warranty.

WARRANTY EXCLUSIONS:

This Warranty does not cover the following:

- Changes in surface finishes as a result of normal use. As a heating appliance, some changes in color of interior and exterior surface finishes may occur. This is not a flaw and is not covered under the Warranty.
- Damage to printed, plated, or enameled surfaces caused by fingerprints, accidents, misuse, scratches, melted items or other external sources and residues left on the plated surfaces from the use of abrasive cleaners or polishes.
- Repair or replacement of parts that are subject to normal wear and tear during the Warranty Period are not covered. These parts include: paint, wood and pellet gaskets, firebricks, grates, flame guides, batteries and the discoloration of glass.
- Minor expansion, contraction, or movement of certain parts causing noise. These conditions are normal and complaints related to this noise are not covered by this Warranty.
- Damages resulting from: (1) failure to install, operate, or maintain the applicable Product in accordance with the installation instructions, operating instructions, and listing agent identification label furnished with the applicable Product; (2) failure to install the applicable Product in accordance with local building codes; (3) shipping or improper handling; (4) improper operation, abuse, misuse, continued operation with damaged, corroded or failed components, accident, or improperly/incorrectly performed repairs; (5) environmental conditions, inadequate ventilation, negative pressure, or drafting caused by tightly sealed constructions, insufficient make-up air supply, or handling devices such as exhaust fans or forced air furnaces or other such causes; (6) use of fuels other than those specified in the operation instructions; (7) installation or use of components not supplied with the applicable Product or any other components not expressly authorized and approved by HHT; (8) modification of the appliance not expressly authorized and approved by HHT in writing; and/or (9) interruptions or fluctuations of electrical power supply to the applicable Product.
- Non-HHT venting components, hearth connections or other accessories used in conjunction with the applicable Product.
- Any part of a pre-existing fireplace system in which an insert or a decorative gas applicable Product is installed.
- HHT's obligation under this Warranty does not extend to the Product's capability to heat the desired space. Information is provided to assist the consumer and the dealer in selecting the proper Product for the application. Consideration must be given to the Product location and configuration, environmental conditions, insulation and air tightness of the structure.

This warranty is void if:

- The applicable Product has been over-fired, operated in atmospheres contaminated by chlorine, fluorine, or other damaging chemicals. Over-firing can be identified by, but not limited to, warped plates or tubes, deformation/warping of interior cast iron structure or components, rust colored cast iron, bubbling, cracking and discoloration of steel or enamel finishes.
- The applicable Product is subjected to prolonged periods of dampness or condensation.
- There is any damage to the applicable Product due to water or weather damage which is the result of, but not limited to, improper chimney or venting installation.

LIMITATIONS OF REMEDIES AND LIABILITY:

- **EXCEPT TO THE EXTENT PROVIDED BY LAW, HHT MAKES NO EXPRESS WARRANTIES OTHER THAN THE WARRANTY SPECIFIED HEREIN. The owner's exclusive remedy and HHT's sole obligation under this Warranty or in contract, tort or otherwise, shall be limited to replacement of the Component Part(s), repair of the Component Part(s), or refund of the original purchase price of the applicable Product(s), as specified above; provided, however, that (i) if HHT is unable to provide replacement of the Component Part(s) and repair of the Component Part(s) is not commercially practicable or cannot be timely made, or (ii) the customer is willing to accept a refund of the purchase price of the applicable Product(s), HHT may discharge all such obligations by refunding the purchase price of the applicable Product. In no event will HHT be liable for any incidental or consequential damages caused by defects in the applicable Product. Some States do not allow the exclusion or limitation of incidental or consequential damages, so the above limitation or exclusion may not apply to you. This Warranty gives you specific legal rights and you may also have other rights which vary from State to State. THE DURATION OF ANY IMPLIED WARRANTY IS LIMITED TO DURATION OF THE EXPRESSED WARRANTY SPECIFIED ABOVE FOR THE APPLICABLE PRODUCT. Some States do not allow limitations on how long an implied warranty lasts, so the above limitation may not apply to you.**

1 Listing and Code Approvals

A. Appliance Safety Certification

Model Number:	CB1200-C
Laboratory:	OMNI Test Laboratories, Inc.
Report Number:	061-S-21-4
Type:	Solid Fuel Room Appliance/Pellet Fuel Burning Type
Standard:	ASTM E1509-12 and ULC S627-00 Room Appliance Pellet Fuel Burning type and (UM) 84-HUD. Mobile Home Approved.

B. Appliance Emissions Certification

Model Number:	CB1200I-C
Laboratory:	OMNI Test Laboratories, Inc.
Report Number:	0061PN013E
Standard:	ASTM E2515, ASTM E2779
Can be found at:	www.quadrafire.com/about-us/epa-certification

This Classic Bay 1200 is Certified to comply with 2020 particulate emission standards.



This pellet appliance needs periodic inspection and repair for proper operation. It is against federal regulations to operate this pellet appliance in a manner inconsistent with operating instructions in this manual.

NOTICE: This installation must conform with local codes. In the absence of local codes you must comply with the **ASTM E1509-12, ULC S627-00 and (UM) 84-HUD.**

C. BTU & Efficiency Specifications

EPA Certification Number:	Number: 176-19
EPA Certified Emissions:	1.0 grams per hour
*LHV Tested Efficiency:	77.8%
**HHV Tested Efficiency:	72.7%
***EPA BTU Output:	11,100 to 30,900 / hr
****BTU Input:	15,900 to 41,100 / hr
Vent Size:	3" or 4" Type "L" or "PL"
Hopper Capacity:	80 lbs.
Fuel:	Premium Wood Pellets
* Weighted average LHV (Low Heating Value) efficiency using data collected during EPA emissions tests in accordance with the requirements of CSA B415.1.	
** Weighted average HHV (High Heating Value) efficiency using data collected during EPA emissions tests in accordance with the requirements of CSA B415.1.	
*** A range of BTU outputs calculated using HHV efficiency and the burn rates from the EPA tests.	
**** Based on the maximum feed rate per hour multiplied by approximately 8600 BTU's which is the average BTU's from a pound of pellets.	

D. Glass Specifications

This appliance is equipped with 5mm ceramic glass. Replace glass only with 5mm ceramic glass. Please contact your dealer for replacement glass.

E. Electrical Rating

115 VAC, 60 Hz, Start 3.75 Amps, Run 1.88 Amps.

F. Mobile Home Approved

- This appliance is approved for mobile home installations when not installed in a sleeping room and when an outside combustion air inlet is provided.
- The structural integrity of the mobile home floor, ceiling, and walls must be maintained.
- The appliance must be properly grounded to the frame of the mobile home and use only Listed pellet vent Class "L" or "PL" connector pipe.
- Outside Air Kit, part 811-0570 or 811-0872 must be installed in a mobile home installation.

G. Sleeping Room

When installed in a sleeping room it is recommended that 3ft of vertical be installed prior to horizontally exiting the room and a smoke/CO alarm be installed in the bedroom. The size of the room must be at least 50ft³ per 1,000 Btu/hr stove input, if the stove exceeds the room size, outside air must be installed.

H. California - Prop65

WARNING

This product and the fuels used to operate this product (wood), and the products of combustion of such fuels, can expose you to chemicals including carbon black, which is known to the State of California to cause cancer, and carbon monoxide, which is known to the State of California to cause birth defects or other reproductive harm. For more information go to: WWW.P65Warnings.ca.gov



WARNING



Fire Risk.

Hearth & Home Technologies disclaims any responsibility for, and the warranty will be voided by, the following actions:

- Installation and use of any damaged appliance.
 - Modification of the appliance.
 - Installation other than as instructed by Hearth & Home Technologies.
 - Installation and/or use of any component part not approved by Hearth & Home Technologies.
 - Operating appliance without fully assembling all components.
 - Operating appliance without legs attached (if supplied with appliance).
 - Do NOT Over fire - If appliance or chimney connector glows, you are over firing.
- Any such action that may cause a fire hazard.

Improper installation, adjustment, alteration, service or maintenance can cause injury or property damage.

For assistance or additional information, consult a qualified installer, service agency or your dealer.

NOTE: Hearth & Home Technologies, manufacturer of this appliance, reserves the right to alter its products, their specifications and/or price without notice.

2 Operating Instructions



WARNING



Do not operate appliance before reading and understanding operating instructions. Failure to operate appliance according to operating instructions could cause fire or injury.

Visit www.quadrafire.com/shopping-tools/videos to view product and use & care videos.

A. Fire Safety

To provide reasonable fire safety, the following should be given serious consideration:

- Install at least one smoke detector on each floor of your home.
- Install at least one carbon monoxide detector on each floor of your home.
- Locate smoke detector away from the heating appliance and close to the sleeping areas.
- Follow the smoke detector manufacturer's placement and installation instructions and maintain regularly.
- Follow the carbon monoxide manufacturer's placement and installation instructions and maintain regularly.
- Conveniently locate a Class A fire extinguisher to contend with small fires.
- In the event of a hopper fire:
 - Evacuate the house immediately.
 - Notify fire department.

B. Non-Combustible Materials

Material which will not ignite and burn, composed of any combination of the following:

- Steel
- Plaster
- Brick
- Iron
- Concrete
- Tile
- Glass
- Slate

Materials reported as passing **ASTM E 136, Standard Test Method for Behavior of Metals, in a Vertical Tube Furnace of 750° C.**

C. Combustible Materials

Material made of/or surfaced with any of the following materials:

- Wood
- Compressed Paper
- Plant Fibers
- Plastic
- Plywood/OSB
- Sheet Rock (drywall)

Any material that can ignite and burn: flame proofed or not, plastered or non-plastered.

D. Fuel Material and Fuel Storage

Pellet fuel quality can greatly fluctuate. We recommend that you buy fuel in multi-ton lots whenever possible. However, we do recommend trying various brands before purchasing multi-ton lots to ensure your satisfaction.

Hearth & Home Technologies strongly recommends only using Pellet Fuel Institute (PFI) certified fuel.

Fuel Material

- Made from sawdust or wood by-products
- Depending on the source material it may have a high or low ash content.

Higher Ash Content Material

- Hardwoods with a high mineral content
- Fuel that contains bark
- Standard grade pellets, high ash pellets

Lower Ash Content Material

- Most softwoods
- Fuels with low mineral content
- Most premium grade pellets



CAUTION

Do not burn fuel that contains an additive; (such as soybean oil).

- May cause hopper fires.
- Damage to product may result.

Clinkers

Minerals and other non-combustible materials such as sand will turn into a hard, glass-like substance called a clinker when heated in the fire pot.

Trees from different areas will vary in mineral content. That is why some fuels produce more clinkers than others.

Moisture

Always burn dry fuel. Burning fuel with high moisture content takes heat from the fuel and tends to cool the appliance, robbing heat from your home. Damp pellet fuel can clog the feed system.

Size

- Pellets are either 1/4 inch or 5/16 inch (6-8mm) in diameter.
- Length should be no more than 1-1/2 inches (38mm).
- Pellet lengths can vary from lot to lot from the same manufacturer.
- Due to length variations, the flame height (feed rate) may need adjusting occasionally.

Performance

- Higher ash content requires the ash drawer to be emptied more frequently.
- Hardwoods require more air to burn properly.
- Premium wood pellets produce the highest heat output.
- Burning pellets longer than 1-1/2 inches (38mm) can cause an inconsistent fuel feed rate and/or missed ignitions.

Changing to Different Fuel Type

- Empty the hopper of the previous fuel.
- Thoroughly vacuum hopper before filling with the new fuel.

The burn rate, BTU content and heat output will all vary depending on the fuel selected.



CAUTION

Tested and approved for wood pellet fuel only. Burning of any other type of fuel voids your warranty.

Storage

- Wood pellets should be left in their original sealed bag until using to prevent moisture absorption.
- Do not store any pellet fuel within the clearance requirements or in an area that would hinder routine cleaning and maintenance.

E. Before Your First Fire

1. First, make sure your appliance has been properly installed and that all safety requirements have been met. Pay particular attention to the fire protection and venting.
2. Double check that the ash drawer and firebox are empty and the fire pot floor is fully closed.
3. Check the position of the thermocouple, located above the fire pot, and make sure that it protrudes approximately 3/4 inch (19mm) into the fire pot.
4. Close and latch the door.



CAUTION

Tip of thermocouple must be in contact with the inside end of the thermocouple cover.
Missed ignitions can occur.

F. Filling the Hopper

Open the hopper lid by lifting the handle. Fill the hopper with fuel. Close the hopper lid. The unit will not feed with the hopper lid open and the fire will go out.

G. General Operating Information

1. Thermostat Calls For Heat

The appliance is like most modern furnaces; when the thermostat calls for heat, your appliance will automatically light and deliver heat. When the room is up to temperature and the thermostat is satisfied, the red call light will go off and the appliance will shut down (**Figure 10.1**).

2. Heat Output Controls

This appliance is equipped with a heat output control switch that has three settings or burn rates; low, medium and high. The appliance will turn on and off as the thermostat demands. When the thermostat calls for heat, the appliance will start up on the high setting for the first 4 minutes and 15 seconds, then automatically switch to the burn rate for which it is set. If the appliance is set at one of the lower settings, it will run quieter but take longer to heat up an area than if it were set at a higher burn rate. Regardless of the burn rate, when the area is warm enough to satisfy the thermostat, the appliance will shut off.

3. Fan Speed Switch

This switch will adjust the speed of the room distribution air fan or convection blower on all three settings. This means you have six different blower speeds available as there is a high and low on each setting.

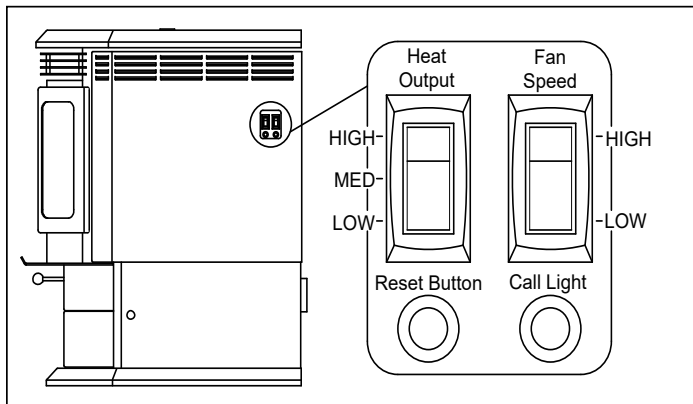



Figure 10.1

H. Starting Your First Fire

1. A thermostat is required for proper operation of this appliance. At this time, fill the hopper with pellets, set the thermostat to its lowest setting. Plug the power cord into nearby outlet.
2. The exhaust blower will stay on for approximately 10 minutes even though the thermostat is not calling for heat. This is normal.
3. Locate the heat output control switch mounted on the right side. Switch it to the high setting by pushing the top of the switch in, then adjust the thermostat to its highest setting. The red call light located on the upper right corner of the right side panel will be on. This indicates the thermostat is calling for heat (**Figure 10.1**).
4. The fuel feed system and the igniter should now be on.

5. For your first fire it will be necessary to press the reset button every two minutes until pellets start to drop into the fire pot, then press button 1 more time. This will fill the feed system and allow the appliance to begin dropping pellets. The appliance will continue to run as long as the thermostat is calling for heat.
6. Once the appliance has ignited, let it burn for approximately 15 minutes, then set the thermostat to the desired room temperature. Adjust the heat output control switch to the desired setting.

 WARNING	
	Fire Risk <u>Do NOT operate appliance:</u> <ul style="list-style-type: none">• With appliance door open.• Fire pot floor open.• Cleaning slide plates open.
	<u>Do NOT store fuel:</u> <ul style="list-style-type: none">• Closer than required clearances to combustibles to appliance• Within space required for loading or ash removal.

I. Fire Characteristics

A properly adjusted fire with the heat output control switch set on “high” has a short active flame pattern that extends out of the fire pot approximately 4 to 6 inches (102 to 152mm). If the fire has tall flames with black tails and seems somewhat lazy, the feed rate will need to be reduced. This is done by sliding the fuel adjustment control rod down, which will reduce the feed. If the fire is not 4 to 6 inches (102 to 152mm) tall, slide the fuel adjustment control rod up to increase the feed. A medium and low setting will give a shorter flame. The flame will rise and fall somewhat. This is normal.

J. Feed Rate Adjustment Instructions

The feed adjustment control rod is factory set, and should be adequate for most fuels. The set screw is located at the bottom of the hopper and *set loose at the factory* so the fuel adjustment control rod will slide up and down by only loosening the thumb screw at the top (**Figure 11.1**). Do not re-tighten bottom set screw.

However, if the flame height is too high or too low, you will need to adjust the feed rate. Wait until the appliance has been burning for 15 minutes before making your adjustments and allow 15 minutes for feed adjustment to take effect.

1. Loosen the thumb screw (**Figure 11.1**).
2. Adjust the fuel adjustment control rod upwards to increase the feed rate and flame height or downwards to decrease the feed rate and flame height.
3. Re-tighten the thumb screw.

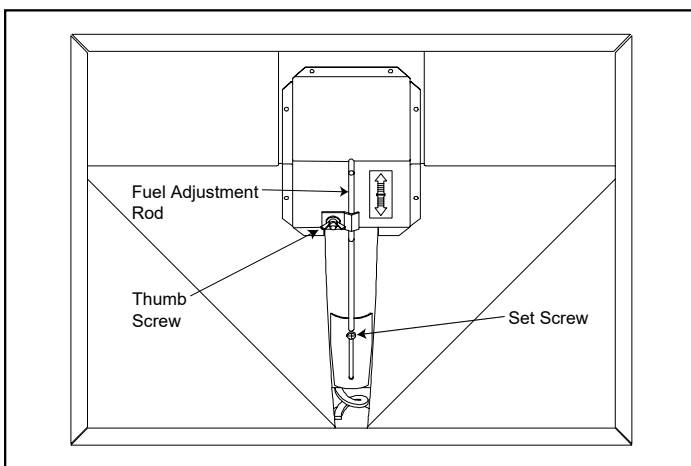

Figure 11.1



CAUTION

Hot while in operation. Keep children, clothing and furniture away. Contact may cause skin burns.

K. Ignition Cycles

1. At the beginning of each ignition cycle, it is normal to see some smoke in the firebox. The smoke will stop once the fire starts.
2. The convection blower will automatically turn on after your appliance has been burning for approximately 10 minutes. This blower transfers heat from your appliance into the room, and will continue to run after the thermostat has stopped calling for heat until the appliance has cooled down.

3. Occasionally the appliance may run out of fuel and shut itself down. When this happens, the red call light will be on (**See Figure 10.1 on page 10**). To restart it, fill the hopper and press the reset button (**Figure 10.1 on page 10**). When you press the reset button the red call light will go out. Release the button and the light will come back on. You should see a fire shortly. If not, follow **Starting Your First Fire on page 10**.



WARNING



Fire Risk

Do NOT operate appliance:

- With appliance door open.
- Fire pot floor open.
- Cleaning slide plates open.

Do NOT store fuel:

- Closer than required clearances to combustibles to appliance.
- Within space required for loading or ash removal.

L. Restarting the Appliance

Restart Process

1. When the unit has run out of fuel, add pellet fuel to the hopper.
2. Dump the ashes and clinkers built up in the fire pot by pulling the ash dump removal handle out several times. Make sure clinkers have dropped into the ash pan then return the handle to fully closed position.
3. Press the reset button; the appliance will then begin its startup sequence.

Restarting After a Power Failure

1. For an electrical disruption the appliance will start on its own without need for priming - providing the control system is asking for heat.

M. Clear Space

Mantel: Avoid placing candles and other heat-sensitive objects on mantel or hearth. Heat may damage these objects.

NOTICE: Clearances may only be reduced by means approved by the regulatory authority having jurisdiction.



WARNING



Fire Risk.

Do NOT operate appliance:

- With appliance door open.
- With fire pot floor open.
- With ash pan removed.



WARNING



Fire Risk.

Keep combustible materials, gasoline and other flammable vapors and liquids clear of appliance.

- Do NOT store flammable materials in the appliance's vicinity.
- **DO NOT USE GASOLINE, LANTERN FUEL, KEROSENE, CHARCOAL LIGHTER FLUID OR SIMILAR LIQUIDS TO START OR "FRESHEN UP" A FIRE IN THIS APPLIANCE.**
- **DO NOT BURN GARBAGE OR FLAMMABLE FLUIDS SUCH AS GASOLINE, NAPHTHA OR ENGINE OIL.**
- **DO NOT USE CHEMICALS OR FLUIDS TO START THE FIRE.**
- Keep all such liquids well away from the appliance while it is in use.
- Combustible materials may ignite.



WARNING



Fire Risk.

Do NOT place combustible objects in front of the appliance. High temperatures may ignite clothing, furniture or draperies. Maintain a minimum clearance of 3 feet (914mm) in front of appliance.

N. Thermostat Controls

TEMPERATURE (HEAT / OFF) SWITCH:

Set this switch to HEAT to control your appliance. The OFF position will disable the appliance.

SET (MULTI-FUNCTION) SLIDE SWITCH:

This provides easy access to common settings, and should always remain in RUN unless items are being adjusted.

NOTE: When thermostat is set to "Manual" non-programmable mode, all positions of the SET slide switch will act like RUN.

UP / DOWN BUTTONS:

The UP and DOWN buttons are used to control the set temperature, or adjust any other on-screen items. An items flashing, is the item currently being adjusted.

HOLD BUTTON:

This button activates and deactivates the manual Temperature HOLD feature, which maintains a fixed set temperature indefinitely without following a program routine.

COPY BUTTON:

This is used to copy temperature program items from one day to the next. Also used to access the menu setup.

NEXT BUTTON:

This is used when setting items such as software options, and temperature programs when they are flashing on the screen. Pressing the NEXT button will cycle through which item is flashing.

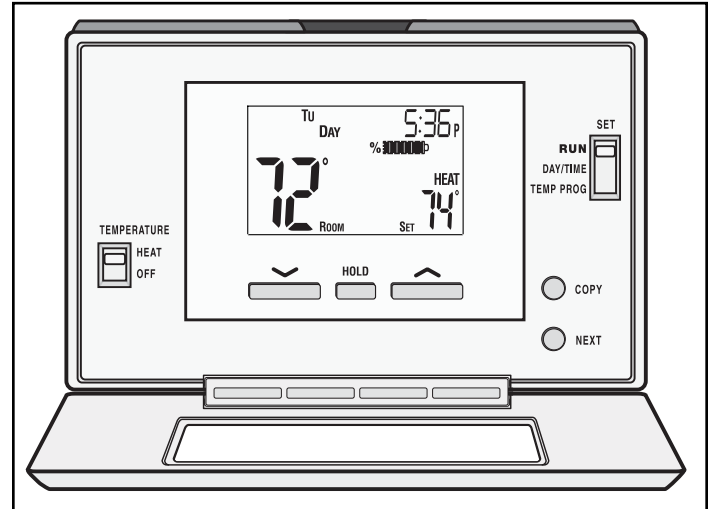

Figure 12.1

O. Thermostat Setup Options

Setup options for how the thermostat will function are performed using a menu on the display screen.

TO ACCESS THE SETUP MENU:

Move the System Mode Switch into the OFF position, and then hold down the COPY button for approximately 5 seconds until the screen changes. The menu will always start with item #01, and is advanced to each following item by a single press of the NEXT button. The options for each item are changed using the UP or DOWN buttons.

ITEM #01 (CLK = CLOCK FORMAT):

- 12Hr, default: This displays the clock times using standard AM and PM values.
- 24Hr: This displays the clock times using the military-time format (example 22:00 hours, without using AM or PM).

ITEM #02 (TMP = TEMPERATURE SCALE):

- F, default: Shows all temperature values in Fahrenheit.
- C: Shows all temperature values Celsius.

ITEM #03 (PROGRAMMING STYLE):

- 7 Day, default: This style uses a separate program routine for each of the 7 days in the week.
- 5/2 Day: This style uses a weekday program routine for Monday, Tuesday, Wednesday, Thursday, Friday, and a separate weekend program routine for Saturday and Sunday.
- Manual Non-Programmable: In this setting, there are no program routines for the thermostat to follow and the temperature control will be set only by the UP and DOWN buttons on the front panel.

ITEM #04 (PERD = EVENT OR PERIOD QUANTITY):

- 4P, default: Thermostat uses four Events per day (called MORN, DAY, EVE, and NITE).
- 2P: The thermostat uses two Events per day (called DAY and NITE).

NOTE: Event or Period Quantity feature is not accessible during Manual Non-Programmable mode.

ITEM #07 (DLAY = DELAY TIME):

- 5, default: Thermostat waits 5 minutes before turning the system back on after it was last run. This internal delay prevents the appliance from turning on too quickly after shutting down. The 5 minute setting is fine for most applications.
- 2: Same operation as above but reduced to 2 minutes between state changes.

NOTE: This delay does not happen when the thermostat is manually turned up and down.

ITEM #08 (TEMPERATURE DIFFERENTIAL):

- The thermostat works by turning your heating system on and off whenever the room temperature varies from the desired set-point temperature.
- Use the UP/DOWN buttons to change the number value between 1 and 9. Generally your system should cycle on about 3 to 6 times per hour. A smaller differential number makes the system cycle more frequently, so the room temperature is more precise and constant. A larger differential number will make the system remain on for a longer duration each time and decreases the number of cycles per hour.
- Default is set to 4.

P. Thermostat Operation Instructions

SET DAY AND TIME:

Place the SET switch into the DAY/TIME position. With the day flashing press UP or DOWN to set the day or the week. Press NEXT and the clock time will start flashing. Use UP or DOWN to set the time; verify the AM/PM indicator is correct. Return the SET switch to RUN position when finished.

HEATING:

Basic operation of the thermostat can be obtained with the SET switch in the RUN position. The temperature can be adjusted using the UP and DOWN buttons. When the thermostat is first powered on, it will follow a default temperature routine that is preset from the factory (**Table 13.1**).

Event	Time	Temperature
MORN	6:00 AM	70°F (21°C)
DAY	8:00 AM	62°F (17°C)
EVE	6:00 PM	70°F (21°C)
NITE	10:00 PM	62°F (17°C)

Table 13.1

LCD DISPLAY BACKLIGHT:

The display screen is lighted to assist viewing at nighttime, or in locations with low light levels. Press any button on the front panel to activate the approximate 10 second backlight.

TEMPERATURE OVERRIDE:

While thermostat is in RUN mode, the set temperature can be temporarily changed by pressing UP or DOWN. The temporarily changed set temperature will return to the programmed value stored in memory when start time of the next upcoming scheduled event is reached (MORN, DAY, EVE, OR NITE). While the temporary changed set temperature is in effect, the word OVERRIDE will be shown on the display screen. To cancel, move TEMPERATURE switch to OFF and back to HEAT again.

TEMPERATURE HOLD:

Temperature hold is used for maintaining a fixed set temperature; once a HOLD is initiated, the thermostat will maintain the set temperature indefinitely. To enter a HOLD state, press the HOLD button one time and the word HOLD will appear on the display. To cancel, press the HOLD button once again.

STATIC NOTICE

Thermostat is protected against normal static electric discharges, however to minimize the risk of damaging the thermostat in extremely dry weather, please touch a grounded metal object before touching the thermostat.

Q. Thermostat Temperature Programs

The thermostat by default has 4 separate program events they are: MORN, DAY, EVE, and NITE. Each event ends at the start time of the following event.

NOTE: If the thermostat is set for 2 events a day instead of 4, the thermostat will only use the DAY and NITE events.

SET TEMPERATURE PROGRAMS:

1. Move TEMPERATURE switch to HEAT.
2. Move SET switch to TEMP PROG position.
3. Starting with Monday, use the UP or DOWN buttons to adjust the start time and set temperature for the MORN event, and then press NEXT button to advance.
4. Adjust the start time and set temperature of the DAY event then press NEXT button.
5. Continue in this same manner to adjust the start time and set temperatures for the EVE and NITE events for Monday

NOTE: When the last event is finished for each day or group of days, the thermostat will advance forward into the next day or group of days.

6. Use steps 3 through 5 to set up the events for the rest of the week or group of days.
7. Return the SET switch back to RUN.

COPY PROGRAM FEATURE:

Using similar instructions as set temperature programs the COPY button will allow a whole day of set program events to be copied to another day.

1. Move Temperature switch to HEAT as well as move SET switch to TEMP PROG position.
2. Starting with Monday, use the UP or DOWN buttons to adjust the start time and set temperature for the MORN, DAY, EVE, and NITE events. Press the COPY button and then press the NEXT button to advance to Tuesday.
3. With Tuesday displayed press COPY button. As all programs events from Monday will be copied to Tuesday (this will advance automatically to the next day; Wednesday, as the word COPY will appear on the screen for one second).

4. Continue in this pressing COPY button to set desired days with original setting.

NOTE: The word COPY will not appear on the display for Monday, but will display each day afterwards for approximately one second and the day of the week will automatically advance forward to the next day.

R. Thermostat Other Features

NOTE: All other features need to be completed in a timely manner as the thermostat will time out after 10 seconds.

TEMPERATURE CALIBRATION:

The internal temperature sensor in this thermostat is accurately calibrated at the factory, and in most cases alterations to this setting should not be needed. The temperature calibration feature allows you to manually offset the measured temperature by as much as plus or minus 5°F (3°C) from its original value. If several thermostats are used in the same house, this feature can be used to synchronize this thermostat to the others.

Change the temperature calibration:

1. Move TEMPERATURE switch to OFF.
2. Move SET switch to RUN.
3. Press and hold both UP and DOWN buttons together for at least 5 seconds; the words SET and CAL will appear on the display along with a single flashing temperature digit.
4. Use the UP or DOWN buttons to change the number of degrees desired for adjustment; 0° is the default value and also means no correction will be applied.
5. Press the NEXT button to accept the setting.

KEYPAD LOCKOUT:

There is the option to lock the front panel buttons to prevent unauthorized tampering of your thermostat settings.

To Lock the Keypad:

1. Move TEMPERATURE switch to HEAT.
2. Move SET switch to RUN.
3. Perform a single press of each button in the following sequence:

- NEXT, NEXT, NEXT, HOLD

A padlock will appear on the display screen.

To Unlock the Keypad:

1. Move TEMPERATURE switch to HEAT.
2. Move SET switch to RUN.
3. Perform a single press of each button in the following sequence:

- NEXT, NEXT, NEXT, HOLD

A padlock will no longer be present on the display screen.

HARDWARE RESET:

The hardware reset button; labeled HW RST, is a small round push button that is located in the middle of the circuit board, just below the battery holder (**Figure 15.1**). Pressing this button will:

- Cause the LCD display screen to become fully populated
- Thermostat to perform an internal system check of its components

If the thermostat appears to be acting in an erratic manner, pressing the HW RST button may remedy this behavior. The temperature programs are not erased when a hardware reset is performed, however the clock will have to be changed to match the current day and time.

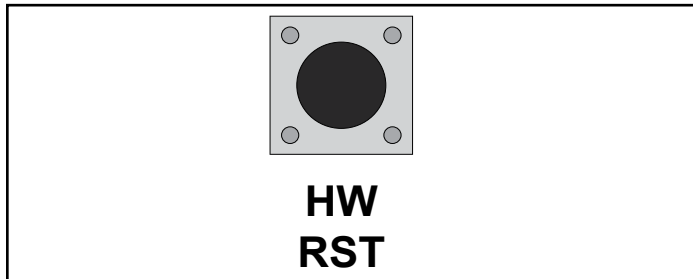

Figure 15.1

SOFTWARE RESET:

Software reset is used to erase ALL temperature events, and to return all user-adjustable software settings back to their original factory default settings.

To Perform a Software Rest:

1. Verify the thermostat's keypad is not locked.
2. Move TEMPERATURE switch to OFF.
3. Press and hold the UP, DOWN, and NEXT buttons all at the same time for at least 5 seconds. When the LCD display screen will become fully populated let go of all buttons at that point the screen will return to normal.

The clock will have to be changed to match the current day and time.

S. Thermostat Battery Replacement

This thermostat is powered by two "AA" Alkaline batteries. The batteries should be replaced AT LEAST once per year to ensure reliable operation or sooner if the LO BATT appears on the display screen. The batteries are located on the back of the thermostat's circuit board. The front portion of the thermostat can be removed from the back half by using the tabs on the top edge of the thermostat housing (**Figure 15.2**).

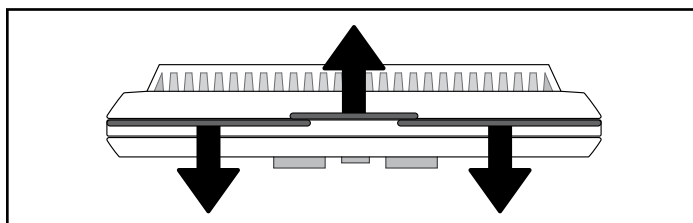

Figure 15.2

When installing new batteries, it is recommended using only brand new "AA" size alkaline batteries. Please verify the polarity markings shown in the battery compartment before adding batteries to the compartment. When finished, line up the front of the thermostat to the base, and firmly press together to securely latch the front and back halves together properly.

BATTERY GRAPHIC:

Anytime the batteries are physically present in the thermostat, there will be a visual indicator showing the life of the battery. This will appear on the display screen (**Figures 15.3 and Figure 15.4**).



Figure 15.3 - Full battery icon



Figure 15.4 - Low battery icon

CONNECT THERMOSTAT WIRES TO APPLIANCE:

There is a 4 screw terminal block located on the back lower left corner of the stove directly above the power cord inlet. The center 2 screws are for the thermostat wires (**Figure 15.5**).

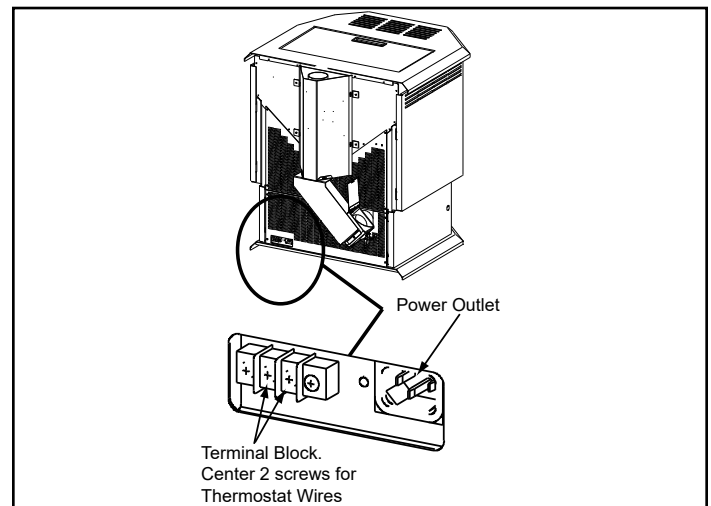



Figure 15.5

**CAUTION**

Shock hazard.

- Do NOT remove grounding prong from plug.
- Plug directly into properly grounded 3 prong receptacle.
- Route cord away from appliance.
- Do NOT route cord under or in front of appliance.



T. Frequently Asked Questions

What causes my glass to become dirty?

If the glass has white ash build up it is normal and the glass should be cleaned. If it is a black soot build up airflow through the unit may be restricted. The most often cause is overdue maintenance and cleaning. See **Maintaining and Service** on [page 17](#) and/or make adjustments to the trim control.

How can I get more heat out of the appliance?

The most often cause of diminished heat output is overdue maintenance and cleaning. See **Maintaining and Servicing** on [page 17](#).

What should I do if I smell smoke or there is ash/soot coming from the appliance?

Seal exhaust venting system to the unit with High Temp silicone. Secure the venting system to the unit with at least (3) screws. All pellet vent pipe must be secured together either by means provided by the pipe manufacturer or by (3) screws at each joint.

In addition most homes are built very tight today and with exhaust systems can create negative pressure in the home. See **Negative Pressure** on [page 15](#) in the [installation manual](#). For ash or soot check the above and the exhaust blower housing and seals.

Why would my appliance run fine last winter but not start this fall?

It is possible that the stove was not properly prepared for the Non-burn season; see **Troubleshooting Guide** on [page 23](#) and [page 24](#).

Is there a place to lubricate the blowers to quiet them down?

No. The most often cause of noisy blowers is from the impellers becoming dirty over time; see **Maintenance and Service** on [page 17](#).

What is the metal object with the bend in it that came inside the plastic bag?

It is a clean-out tool used to help clean the fire pot and remove any jams in the rare event they occur in the feed tube.

Why is there a black residue building up on the outside of my home?

Wind can cause this to happen. If the appliance is operating correctly very little soot should ever exit the termination cap. Check to be sure the venting is installed per the **Install Guide** starting on [page 5](#) of the [installation manual](#) and check your local codes.

Do I need an outside air kit?

Outside air is required for mobile home installs and in some jurisdictions. Refer to **Listing & Code Approvals** on [page 6](#), **Mobile Home Installation** on [page 24](#) in the [installation manual](#) and **Appliance Set-up** on [page 20](#) in the [installation manual](#). Also refer to local building codes.

I am seeing sparks coming out of my pipe (termination cap) outside is this safe?

This is normal. As long as **Clearances to Combustibles** on [page 10](#) of the [installation manual](#) were followed this is safe.

I have no power to anything. Does this appliance have a circuit breaker or fuse or a reset button?

This unit has one fuse on the control board and a resettable snap disc mounted to the feed tube. If the appliance overheats then the snap disc can be reset; if the fuse is blown the control board must be replaced.

Where is the serial number located on this appliance?

The serial number is located on the back of the appliance.

No pellets are dropping in my fire pot.

See **Troubleshooting Guide** on [page 23](#).

Contact your dealer for additional information regarding operation and troubleshooting.
Visit www.quadrafire.com to locate a dealer.

3 Maintenance and Service

When properly maintained, your appliance will give you many years of trouble-free service. Contact your dealer to answer question regarding proper operation, troubleshooting and service for your appliance. Visit www.quadrafire.com/owner-resources to view basic troubleshooting, FAQs, use & care videos. We recommend annual service by a qualified service technician.

A. Proper Shutdown Procedure

Turn off the thermostat.

This pellet appliance has a manufacturer-set minimum low burn rate that must not be altered. It is against federal regulations to alter this setting or otherwise operate this pellet appliance in a manner inconsistent with operating instructions in this manual.

Follow the detailed instructions found in this section for each step listed in the chart below.

B. Quick Reference Maintenance Chart

Cleaning or Inspection	Frequency		Daily	Weekly	Monthly	Yearly
Ash Pan (Wood Pellets)	Every 5 bags of fuel	OR		X		
Ash Removal from Firebox	More frequently depending on the fuel type or ash build-up	OR		X		
Beneath Heat Exchanger	Every 1 ton of fuel	OR			X	
Blower, Combustion (Exhaust)	More frequently depending on the fuel type	OR				X
Blower, Convection	More frequently depending on operating environment	OR				X
Door Latch Inspection	Prior to heating season	OR			X	
Exhaust Path	More frequently depending on ash build-up	OR				X
Firebox - Prepare for Non-Burn Season	At end of heating season	OR				X
Fire pot - Burning pellets - hardwood	Every 3 bags	OR	X			
Fire pot - Burning pellets - softwood	Every 5 bags	OR	X			
Glass	When clear view of fire pot becomes obscure	OR		X		
Heat Exchanger & Drop Tube	Every 1 ton of fuel	OR			X	
Hopper	Every 1 ton of fuel or when changing fuel types	OR			X	
Top Vent Adapter	More frequently depending on the fuel type or ash build-up	OR				X
Venting System	More frequently depending on the fuel type	OR				X

NOTICE: These are recommendations. Clean more frequently if you encounter heavy build-up of ash at the recommended interval or you see soot coming from the vent. Not properly cleaning your appliance on a regular basis will void your warranty.

CAUTION



Shock and Smoke Hazard

- Turn down thermostat, let appliance completely cool and exhaust blower must be off. Now you can unplug appliance before servicing.
- Smoke spillage into room can occur if appliance is not cool before unplugging.
- Risk of shock if appliance not unplugged before servicing appliance.

C. General Maintenance and Cleaning

1. Types of Fuel

The type of fuel you are burning will dictate how often you have to clean your fire pot.

If the fuel you are burning has a high dirt or ash content, it may be necessary to clean the fire pot more than once a day.

Dirty fuel will cause clinkers to form in the firepot (**Figure 18.1**). A clinker is formed when dirt, ash or a non-burnable substance is heated to 2000°F (1093°C) and becomes glass-like. See **High Ash Fuel Content Maintenance** on **page 22** for more details on different types of fuels.

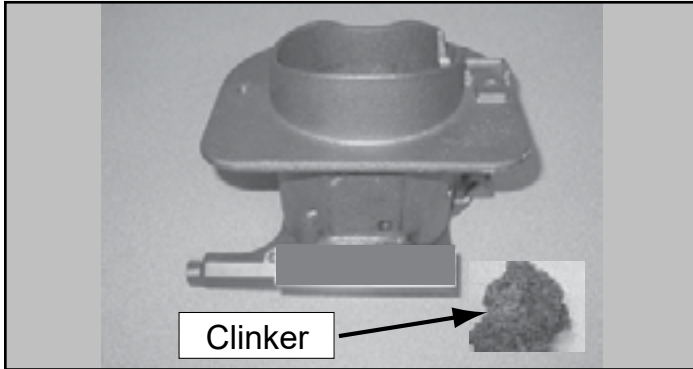



Figure 18.1

2. Cleaning Fire pot with Cleaning Rod & Fire pot Scraper

- **Frequency:** Daily or more often as needed
- **By:** Homeowner
 - a. The appliance must be in complete shutdown and cool and the exhaust blower off.

NOTE: If you are just cleaning the fire pot, there is no need to unplug the insert.

- b. Pull fire pot cleaning rod OUT a couple of times to help shake debris loose. If rod is hard to pull, it may be necessary to use your fire pot clean-out tool to chip away material that has built up on the bottom plate of the fire pot and to push out any clinkers. Larger clinkers may have to be removed from the top of the fire pot.
- c. The fire pot floor plate must be fully closed when finished (**Figure 18.2**).

 WARNING	
	Fire Risk
	<ul style="list-style-type: none">• NEVER pull fire pot cleaning rod or cleaning slide plates out when appliance is operating.• The cleaning slide plates must be fully CLOSED when appliance is operating.
	<ul style="list-style-type: none">• Hot pellets may fall into ash pan and start a fire or mis-starts due to lack of vacuum.

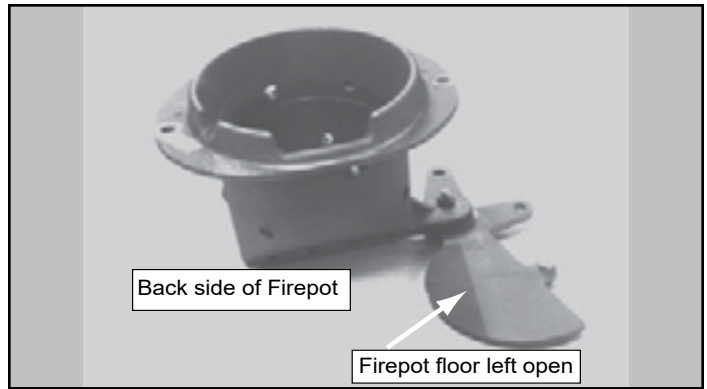

Figure 18.2



3. Ash Removal from Firebox

- **Frequency:** Every 5 bags or weekly or more frequently depending on ash build-up.
- **By:** Homeowner
 - a. There must not be any hot ashes in the firebox during cleaning so allow the appliance to completely cool. The firebox ash should be removed every time the exhaust path is cleaned. Frequent cleaning of the ash in the firebox will help slow down the build-up of ash in the exhaust blower and vent system.
 - b. Plug in your appliance, if unplugged, and turn the thermostat on and immediately shut it off to start the exhaust blower on its cycle time. It will pull fly ash out the exhaust instead of into the room.
 - c. Open door. Remove ash with an ash vacuum or whisk broom and small dust pan.
 - d. This ash is deposited in the same ash pan as the fire pot debris. The ash pan should be emptied every time you clean the firebox. Remember to place the ash and debris into a metal or noncombustible container.
 - e. The cleaning rods must be fully closed when cleaning is complete; see **Disposal of Ashes** on **page 19**.

4. Cleaning Ash Pan

- **Frequency:** Weekly or every 5 bags of fuel
- **By:** Homeowner

Empty into a non-combustible container and re-install ash pan; see **Disposal of Ashes** on **page 19**.



 WARNING	
	Fire Risk
	<ul style="list-style-type: none">• The cleaning slide plates must be fully CLOSED when appliance is operating. Hot pellets may fall into ash pan and start a fire.

5. Disposal of Ashes

- **Frequency:** As needed
- **By:** Homeowner

Ashes should be placed in a steel container with a tight-fitting lid. The container of ashes should be moved outdoors immediately and placed on a non-combustible floor or on the ground, well away from all combustible materials, pending final disposal.

If the ashes are disposed of by burial in soil or otherwise locally dispersed, they should be retained in the closed container until all cinders have thoroughly cooled. Other waste shall not be placed in this container.

 WARNING	
	Disposal of Ashes
	<ul style="list-style-type: none">• Ashes should be placed in metal container with tight fitting lid.• Ashes should be retained in closed container until all cinders have thoroughly cooled.

6. Cleaning Heat Exchanger Chambers & Drop Tube

- **Frequency:** Monthly or every 1 ton of fuel
- **By:** Homeowner

The amount of ash buildup in the fire pot will be a good guide to determine how often you should clean the heat exchangers.

- Allow the appliance to completely cool down before pulling the cleaning rods. Turn the thermostat on and then immediately off to start the exhaust blower on its cycle time. It will pull fly ash out the exhaust instead of into the room.
- To access the cleaning rods lift the hopper lid. Both black bent handle pull rods are located close to the face of the appliance to the left and right side.
- To clean, pull the rods straight out until it stops, approximately 20 inches (508mm). Slide the rods OUT and IN a couple of times.

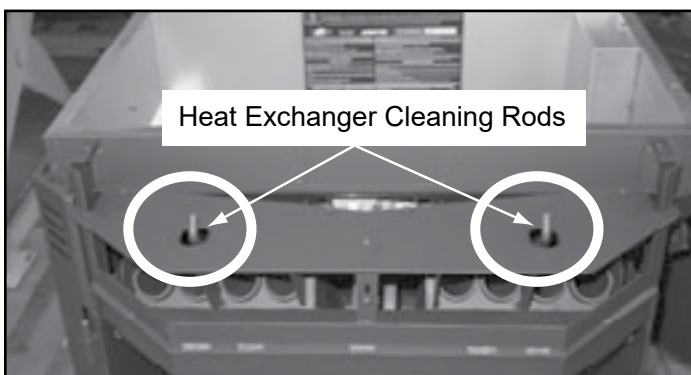

Figure 19.1

7. Cleaning Beneath Heat Exchanger

- **Frequency:** Monthly or after burning 1 ton of fuel
- **By:** Homeowner
 - Be sure the appliance is allowed to cool, has been unplugged and the exhaust blower is off.
 - A more thorough cleaning is needed to remove the excess ash that is left behind from the use of the cleaning rods for the heat exchanger tubes.
 - The ash will be resting on the back of the baffle. This will require removing the baffle; see **Baffles** on [page 26](#).

8. Cleaning the Exhaust Path

- **Frequency:** Every 25 bags or monthly or more frequently depending on ash build-up.
- **By:** Homeowner
 - Be sure the appliance is allowed to cool, has been unplugged and the exhaust blower is off.
 - Remove access door on the right of the appliance (4 screws).
 - Use a small vacuum hose attachment to clean area.
 - Re-install and close trap door.

9. Cleaning the Hopper

- **Frequency:** Monthly or after burning 50 bags of fuel or when changing fuel type
- **By:** Homeowner

After burning approximately 1 ton of fuel or changing fuels you will need to clean the hopper to prevent sawdust build-up.

A combination of sawdust and pellets on the auger reduces the amount of fuel supply to the fire pot. This can result in nuisance shutdowns and mis-starts.

- Be sure the appliance is allowed to cool, has been unplugged and the exhaust blower is off.
- Empty the hopper of any remaining pellets.
- Vacuum the hopper and feed tube.

NOTE: Hearth & Home Technologies recommends to use a heavy duty vacuum cleaners specifically designed for solid fuel appliance cleaning.

10. Soot and Fly Ash: Formation & Need for Removal in Exhaust Venting System.

- **Frequency:** Yearly or more frequently depending on ash build-up.
- **By:** Qualified Service Technician/Homeowner

Be sure the appliance is allowed to cool, has been unplugged and the exhaust blower is off.

The products of combustion will contain small particles of fly ash. The fly ash will collect in the exhaust venting system and restrict the flow of the flue gases.

At start-up if there is incomplete combustion, or if there is a shutdown or incorrect operation of the appliance it will lead to some soot formation. This will collect in the exhaust venting system.

The venting system may need to be cleaned at least once a year or more often depending upon the quality of your fuel or if there is a lot of horizontal pipe sections. Ash will build up more quickly in the horizontal sections.

11. Cleaning the Glass

- **Frequency:** When clear view of the fire pot becomes obscure
- **By:** Homeowner
 - a. Appliance must be completely cool before cleaning glass.
 - b. Vacuum fly ash from glass and door rope.
 - c. Use a damp paper towel or any non-abrasive glass cleaner. Wipe off with dry towel.

 **CAUTION**

 Handle glass assembly with care.

When cleaning glass:

- Avoid striking, scratching or slamming glass.
- Do NOT clean glass when hot.
- Do NOT use abrasive cleaners.
- Use a hard water deposit glass cleaner on white film.
- Refer to maintenance instructions.

 **WARNING**

 Handle glass doors with care.

- Inspect the gasket to ensure it is undamaged.
- Do NOT strike, slam or scratch glass.
- Do NOT operate appliance with glass door removed, cracked, broken or scratched.

12. Door Latch Inspection

- **Frequency:** Prior to heating season
- **By:** Homeowner
 - a. Be sure the appliance is allowed to cool, has been unplugged and the exhaust blower is off.
 - b. To adjust, open the latch and pivot the holding rod out. Loosen the jam nut on the rod.
 - c. With a Phillips head screw driver, turn the rod clockwise to tighten. The latch handle should snap securely in place when adjusted properly.
 - d. After adjusting the latch, be sure to tighten the jam nut on the rod to hold the adjustment.

13. Cleaning Exhaust Blower - Requires No Lubrication

- **Frequency:** Yearly or as needed
- **By:** Qualified Service Technician
- **Task:** Contact your local dealer

14. Cleaning Convection Blower - Requires No Lubrication

- **Frequency:** Yearly or as needed
- **By:** Qualified Service Technician
- **Task:** Contact your local dealer.

15. Cleaning the Top Vent Adapter

- a. The appliance must be in complete shutdown and the exhaust blower should be off. Allow the appliance to completely cool down.
- b. Open the clean-out cover (**Figure 20.1**).
- c. Sweep out any ash build-up.

NOTE: There are heavy duty vacuum cleaners specifically designed for solid fuel appliance cleaning.

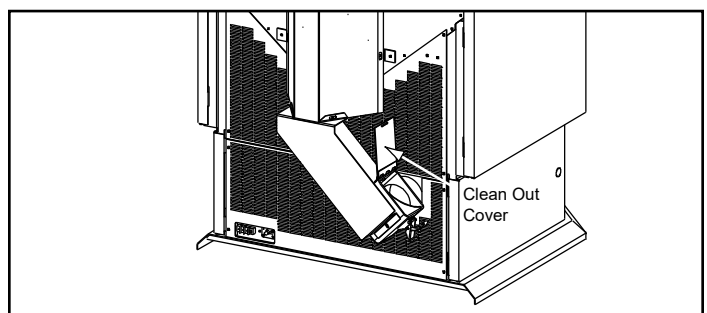

Figure 20.1

16. Preparing Firebox for Non-Burn Season

- **Frequency:** Yearly at the end of the heating season
- **By:** Homeowner
 - a. Be sure the appliance is allowed to cool, has been unplugged and the exhaust blower is off.
 - b. Remove all ash from the firebox and vacuum thoroughly.
 - c. Paint all exposed steel, including cast-iron.
 - Use the Touch-Up paint supplied with the appliance; **or**;
 - Purchase paint from your local dealer.
 - Must use a high-temperature paint made specifically for heating appliances.

17. Door Gasket Inspection

- **Frequency:** Prior to heating season
- **By:** Homeowner
 - a. Be sure the appliance is allowed to cool, has been unplugged and the exhaust blower is off.
 - b. To inspect the door rope (gasket), open the door and see that the door rope extends approximately 1/8 inch (3mm) to 3/16 inch (9.5mm) from the door rope channel.
 - c. It should show signs of compaction all the way around the door where the rope contacts the face of the appliance. Confirm there are no air leaks.

18. Vacuum Heat Exchanger Tubes, Firebox Area and Drop Tube

- a. Use a Shop Vac to vacuum any fly ash and soot from the heat exchanger tubes and firebox area (**Figure 21.1**).
- b. Remove any debris that may be in the drop tube.

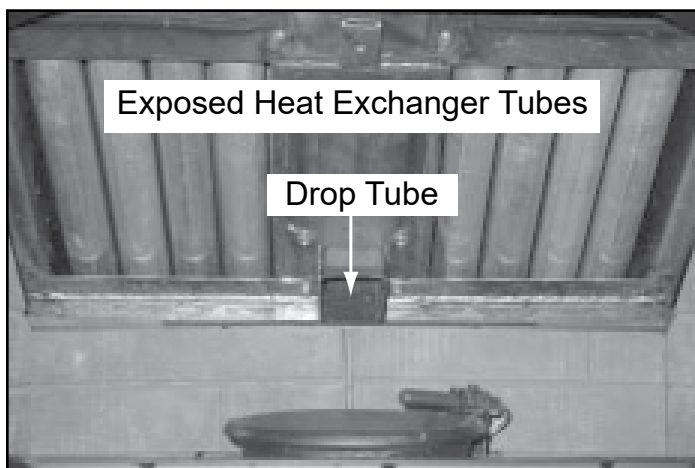

Figure 21.1

19. Clean Exhaust Exit Behind the Exhaust Blower

- a. Open both the upper and lower right side panels (**Figure 21.2**).
- b. Using a Phillips head screwdriver remove the 4 screws from the clean-out plate and set aside (**Figure 21.2**).
- c. Use a small vacuum hose attachment to clean area (**Figure 21.3**).
- d. Re-attach clean-out plate and close side panels.

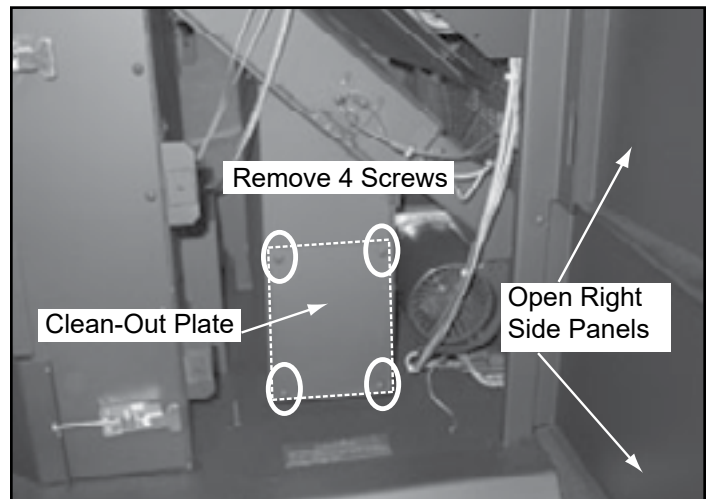

Figure 21.2

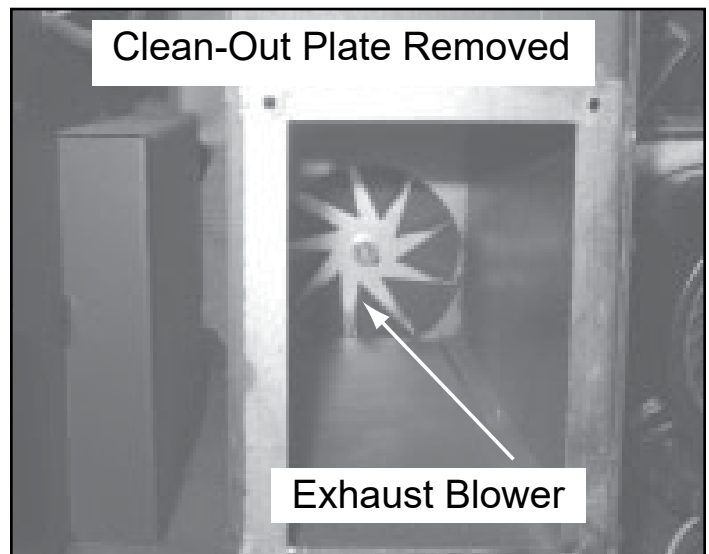

Figure 21.3

D. Soot or Creosote Fire

Establish a routine for the fuel, wood burner and firing technique. Check daily for creosote build-up until experience shows how often you need to clean to be safe. Be aware that the hotter the fire the less creosote is deposited, and weekly cleaning may be necessary in the mild weather even though monthly cleaning may be enough in the coldest months. Contact your local municipal or provincial fire authority for information on how to handle a chimney fire.

In the event of a soot or creosote fire, close the firebox door, exit the building immediately and contact the proper fire authorities.

DO NOT under any circumstances re-enter the building.

E. High Ash Fuel Content Maintenance

- **Frequency:** As needed
- **By:** Homeowner

Poor quality pellet fuel, or lack of maintenance, can create conditions that make the fire pot fill quickly with ashes and clinkers.

This condition makes the appliance susceptible to overfilling the fire pot with pellets which may result in smoking, sooting and possible hopper fires. **Figure 22.1** shows an example where the fire pot overfills, pellets back up into the feed tube and ash has accumulated in the firebox.

An inefficient and non-economical method of burning of fuel caused by poor quality pellet fuel is shown in **Figure 22.2**.

The correct flame size when good quality, premium pellet fuel is burned is shown in **Figure 22.3**.

If the ash buildup exceeds the half way point in the fire pot **IMMEDIATE ATTENTION AND CLEANING IS REQUIRED.**

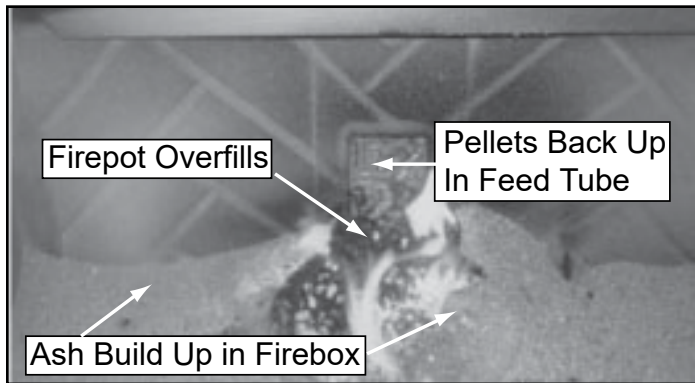

Figure 22.1

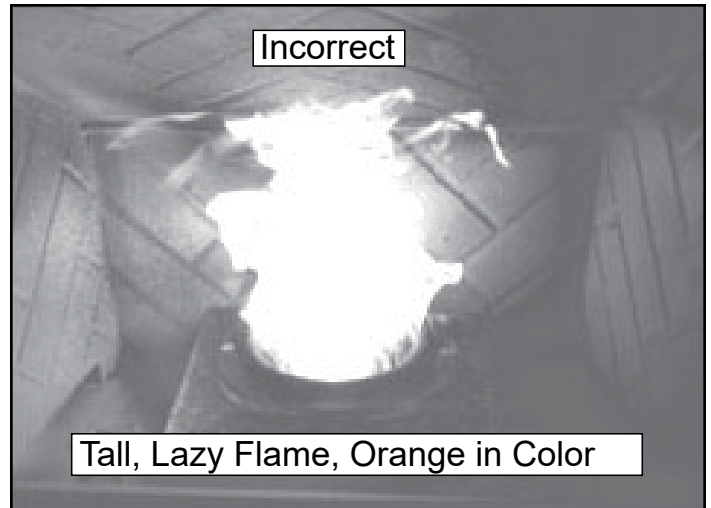

Figure 22.2

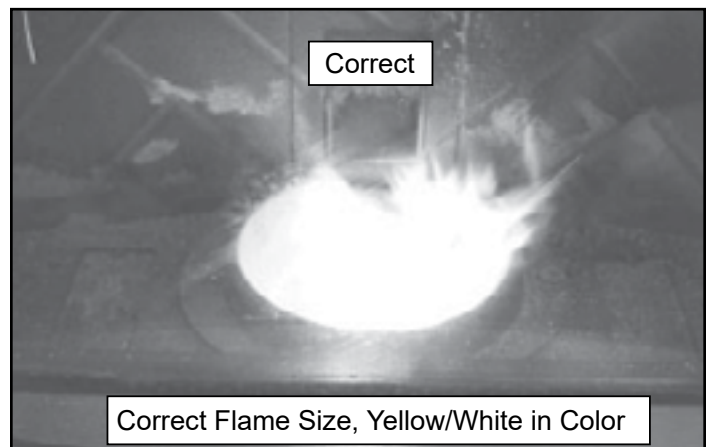

Figure 22.3

4 Troubleshooting Guide

With proper installation, operation, and maintenance your appliance will provide years of trouble-free service. If you do experience a problem, this troubleshooting guide will assist a qualified service person in the diagnosis of a problem and the corrective action to be taken. **This troubleshooting guide can only be used by a qualified service technician.**

Symptom	Possible Cause	Corrective Action
Plug in appliance - No response.	No current to outlet. 7 amp fuse defective. #3 snap disc tripped or defective. Control box defective.	Check circuit breaker at service panel. Replace fuse. Reset or replace snap disc. Replace control box.
Call light on. No fire. No fuel in fire pot.	Out of fuel. #2 snap disc may be defective. Vacuum switch not closing, no vacuum. Control box defective.	Check hopper. Fill with fuel. Replace snap disc. Check exhaust blower is plugged in and operating. Check vacuum switch is plugged in. Check vacuum hose is in good condition, clear and connected at both ends. Check thermocouple is in good condition and plugged in properly. Make sure venting system is clean. Make sure front door is closed. Replace control box.
Call light on. No fire. Partially burned fuel in fire pot.	Fire pot clean-out plate not closed. Fire pot is dirty (missed ignition).	Check that fire pot clean-out plate is fully closed. Clean fire pot. Make sure there is no clinker in the fire pot; see Cleaning Fire pot with Cleaning Rod & Fire pot Scraper on page 18 . Clinkers may have to be broken up with fire pot clean-out tool or other means.
Call light on. No fire. Unburned pellets in fire pot.	Fire pot clean-out plate not closed. Fire pot is dirty. The ignition hole between the igniter bracket and fire pot is blocked. Igniter not working. Control box defective.	Check that fire pot clean-out plate is fully closed. Clean fire pot. Make sure there is not a clinker in the fire pot. Clinkers may have to be pushed out of fire pot with fire pot clean-out tool or other means. Scrape with solid piece of wire. Remove ash drawer to see if igniter is glowing red on start-up. Check igniter wires for good connection. Replace igniter using 1/4 inch (6mm) male / female spade connectors. Replace control box.
Slow or smoky start-up.	Fire pot clean-out plate not closed. Fire pot is dirty. Excessive amount of fuel at start-up. Dirty exhaust and/or venting system.	Check that fire pot clean-out is fully closed. Clean fire pot. Make sure there is not a clinker in the fire pot. Clinkers may have to be pushed out of fire pot with fire pot clean-out tool or other means. Reduce feed rate using feed rate adjustment control rod located inside hopper. Check for ash build up in appliance, including behind rear panels, firebox, heat exchanger, exhaust blower and venting.
No call light. Appliance does not begin start sequence.	Thermostat not set to a high enough temperature. Snap Disc #3 tripped. No power. Fuse blown. Connections at thermostat and/or appliance not making proper contact. Defective thermostat or thermostat wiring. Control box defective.	Adjust thermostat above room temperature. Reset snap disc. Connect to power. Replace fuse. Check connections at thermostat and appliance. Replace thermostat or wiring. NOTE: To test thermostat and wiring, use a jumper wire at the thermostat block on the appliance to by-pass thermostat and wiring. Replace control box.

Symptom	Possible Cause	Corrective Action
Feed system fails to start.	Out of fuel. #2 snap disc may be defective. Vacuum switch not closing. No vacuum. Feed system jammed or blocked. Feed spring not turning with feed motor. Feed motor defective or not plugged in.	Check hopper, fill with fuel. Replace snap disc. Firebox door must be closed securely. Check exhaust blower is plugged in and operating. Check vacuum switch is plugged in. Check vacuum hose is in good condition, clear and connected at both ends. Check thermocouple is in good condition and plugged in properly. Make sure venting system is clean. NOTE: High winds blowing into the venting system can pressurize the firebox causing loss of vacuum. Empty hopper of fuel. Use a wet/dry vacuum cleaner to remove remaining fuel, from hopper, including feed tube. Check feed chute for obstructions. Loosen 2 screws and jiggle feed assembly. Check that set screw is tight on feed spring shaft at end of feed motor. Check connections on feed motor, replace if defective.
Appliance fails to shut off.	Call light on.	Turn thermostat off. If call light does not go out, disconnect thermostat wires from appliance. If call light does go out, thermostat or wires are defective.
Convection blower fails to start	#1 snap disc defective. Blower not plugged in. Blower is defective. Control box is defective.	Replace snap disc. Check that blower is plugged into wire harness. Replace blower. Replace control box.
Exhaust blower fails to start or does not shut off.	Blower not plugged in. Blower is clogged with ash. Blower is defective. Control box is defective.	Check that blower is plugged into wire harness. Clean exhaust system. Replace blower. Replace control box
Large, lazy flame, orange color. Black ash on glass.	Dirty appliance. Poor fuel quality, high ash content. Fire pot clean-out plate not completely closed. Excessive amount of fuel.	Clean appliance, including fire pot, heat exchangers and venting system. Remove stainless steel baffle from firebox to clean ash from on top of baffle. Clean behind rear brick panels. Change fuel brand to premium. Check that fire pot clean-out plate is fully closed. Reduce feed rate using feed rate adjustment control rod located inside hopper.
Nuisance shutdowns.	Low flame. Sawdust buildup in hopper. Feed motor is reversing. Defective thermocouple. Defective control box. Fire pot more than 1/2 full.	Increase feed by opening feed rate adjustment control rod located inside hopper. Clean hopper, see Cleaning The Hopper on page 19 . Check for good connections between feed motor and wire harness. Replace thermocouple. Replace control box. See High Ash Fuel Content Management on page 22
Appliance calls for heat. Call light illuminates. Exhaust blower starts. No feed or igniter.	Thermocouple is defective or not properly plugged in. Defective control box	Check connections on thermocouple or replace if defective. A flashing yellow light on the control box indicates a problem with the thermocouple. Replace control box.
Hopper lid not closed all the way	Switch or magnet is out of adjustment (auger will not function)	Close the lid. If that doesn't work, adjust or replace the switch or magnet

5 Service Parts Replacement

A. Blowers

1. Exhaust Blower - PART NUMBER: 812-3381

Remove existing blower:



- Use proper shut down procedures to shut down the appliance and let it completely cool and then unplug it.
- Use an 11/32" wrench or nut driver to loosen and remove the (6) nuts holding motor mount plate to the blower housing on your appliance.
- Remove washer from beneath the terminal ring on the grounding wire.
- Pull motor/mounting plate from blower housing.
- Scrape off old gasket material from blower housing.

Install new blower:

- The blower and blower housing is shipped as an assembly. It is necessary to separate them at this point if you are using the existing blower housing already installed on the appliance.
- Follow steps 2 and 3 above. Discard or set aside the new blower housing.
- Carefully remove gasket from new housing and set onto the blower housing.

Re-install blower to blower housing:

- Install blower on housing ensuring that wiring exits facing the 8 o'clock position. Place the washer and then the grounding wire on nearest mounting plate stud.
- Use nuts removed in **Step b of Remove existing blower** to secure blower to housing.
- Re-connect wiring (use jumper wire if necessary). Re-connect power supply.

	CAUTION
	Shock Risk. <ul style="list-style-type: none">Do NOT remove grounding prong from plug.Plug directly into properly grounded 3 prong receptacle.
	<ul style="list-style-type: none">Route cord away from appliance.Do NOT route cord under or in front of appliance.

2. Convection Blower - PART NUMBER: 812-3370

- Use proper shut down procedures to shut down the appliance and let it completely cool.
- The convection blower is located at the bottom rear of the appliance. If an outside air kit is also installed, depending on your particular installation you may or may not have to remove the outside air flange. If you do, remove the 2 screws using a Phillips head screwdriver. You do not need to remove the flex pipe from the flange.
- Remove the lower rear screen by removing the 4 screws securing the screen to the appliance.
- The motor is mounted on a removable bracket. Remove the 2 screws just above the motor and the whole assembly will tilt down and pull out.
- Disconnect the wires from the blower. The wires coming from the wiring harness are white, red and tan and the wires coming from the blower are black, white and red. The white connects to white, the red to red and black to the tan color wire.

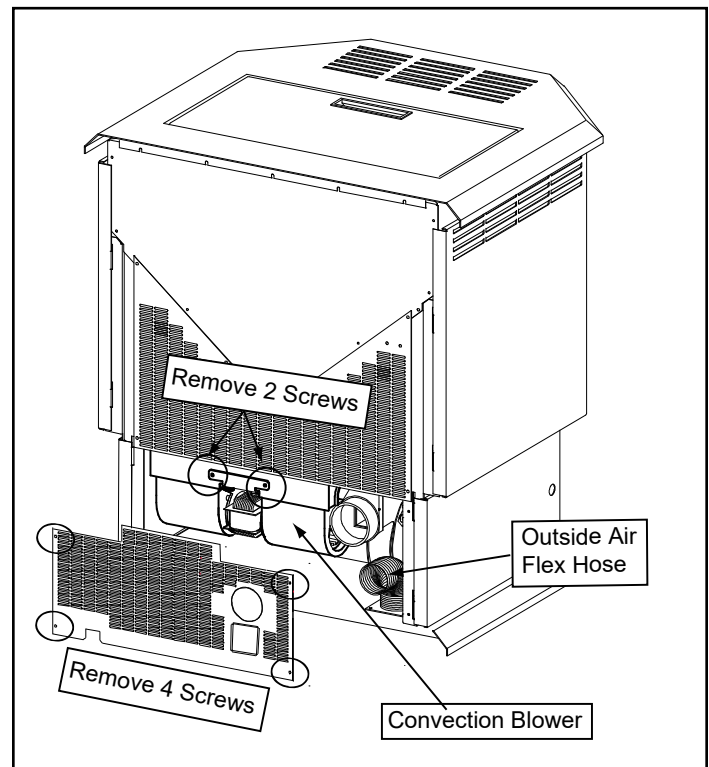

Figure 25.2

B. Baffles

PART NUMBERS: LEFT BAFFLE: 510-5350, RIGHT BAFFLE: 510-5360

1. Use proper shut down procedures to shut down the appliance and let it completely cool down.
2. Open right side panel and then open the door.
3. The 2 baffles are located at the top inside of firebox.
4. Place your hand on the baffle and slide it up and the bottom edge will fall down and then you can lift the baffle out. Repeat for the other side.

a. Remove Baffle to Access Heat Exchanger Tubes and Firebox Exhaust Exits

- i. Open the upper right side panel door and then open the glass door.
- ii. The 2 baffles are located at the top inside of firebox.
- iii. Place your hand on the baffle and slide it up and the bottom edge will fall down and then you can lift the baffle out. Repeat for the other side.
- iv. Re-install in reverse order.

C. Igniter

PART NUMBER: SRV7000-462

1. Use proper shut down procedures to shut down the appliance and let it completely cool down and then unplug it and remove the ash drawer.
2. Follow instructions to remove the ash pan found on [page 18](#) - **Cleaning Ash Pan**. Remove the access plate directly above it by removing the 2 screws just below the ash catcher.
3. The wire leads to the igniter are connected to the wire harness with 1/4 inch male / female spade connectors. These wires will pull forward approximately 4 to 5 inches (102mm to 127mm). Disconnect the spade connections and remove the igniter from the chamber. Loosen the thumb screw and slide igniter out.
4. Install new igniter into the chamber and tighten the thumb screw. Re-connect the wires to the 2 leads with the spade connectors.
5. Remove right side panel and pull wire leads back toward the rear of the appliance to take-up the 4 to 5 inches (102mm to 107mm) previously pulled out. This will keep the wires out of the way of the ash drawer. Double check that the igniter wires are clear of any movement, i.e. ash drawer, fire pot cleaning rod, etc.
6. Re-install the ash drawer and side panel and re-connect the power.

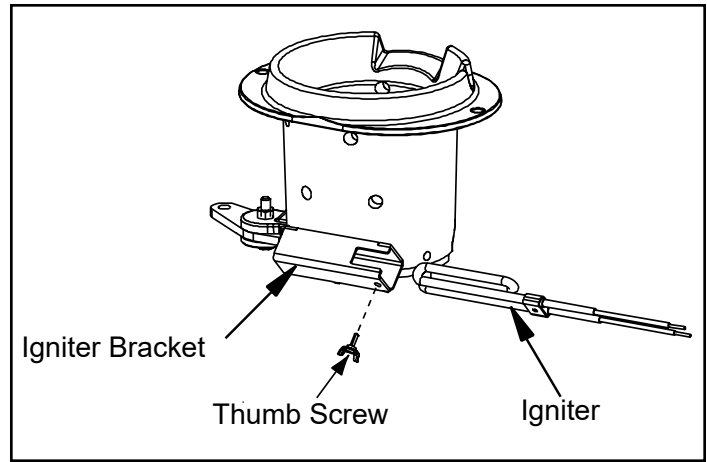

Figure 26.1



CAUTION



Shock Risk.

- Do NOT remove grounding prong from plug.
- Plug directly into properly grounded 3 prong receptacle.
- Route cord away from appliance.
- Do NOT route cord under or in front of appliance.

D. Glass



WARNING



- Glass is 5mm thick high temperature heat-resistant ceramic glass.
- **DO NOT REPLACE** with any other material.
- Alternate material may shatter and cause injury.

PART NUMBERS:

LEFT OR RIGHT SIDE GLASS: 510-5400

CENTER BAFFLE: 510-5410

- Remove door from appliance and place face down on a protected surface to avoid scratching the door.
- Remove all door rope.

NOTE: DO NOT LET Air Wash Spacers fall down from top frame when removing and replacing center glass.

1. Center Glass

- Be sure the appliance is allowed to cool, has been unplugged and the exhaust blower is off.
- Using a nut driver remove the (5) bottom nuts and remove the bottom glass frame (**Figure 27.1**).
- Slightly bend up and out of the way the 2 center posts and slide the glass out the bottom.
- Slide new glass in, reposition the 2 center posts and re-install bottom glass frame.
- Re-rope the door.

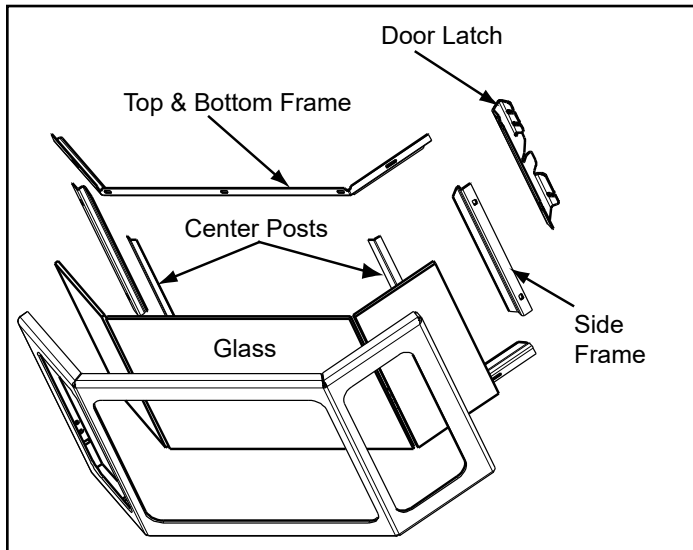

Figure 27.1

2. Side Glass

NOTE: When removing the side glass with the door latch, you must remove the door latch first before removing the side frame. Use a powered Phillips head screw driver to remove the 4 screws.

- Be sure the appliance is allowed to cool, has been unplugged and the exhaust blower is off.
- Remove side glass frame.
- Loosen the top and bottom frame and slightly bend up and out of the way.
- Slide glass out the side and slide new glass in.
- Re-install the side glass frame and tighten the top and bottom frames.
- Re-install the door latch, if applicable, and re-rope the door.

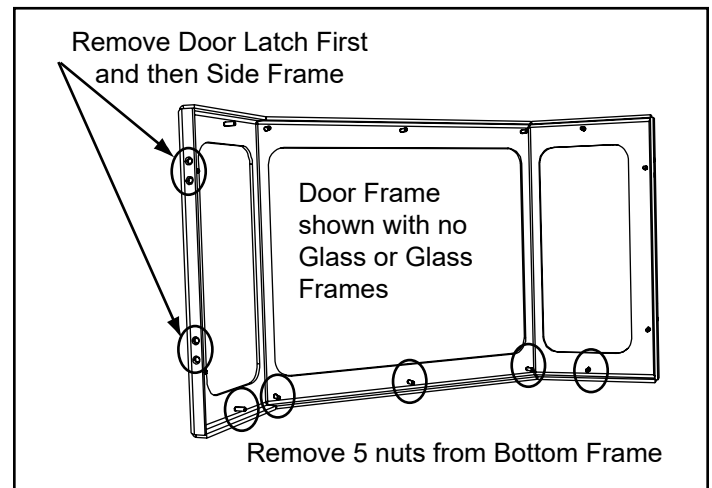

Figure 27.2



CAUTION



Handle glass assembly with care.
When cleaning glass:

- Avoid striking, scratching or slamming glass.
- Do NOT clean glass when it is hot.
- Do NOT use abrasive cleaners.
- Use a hard water deposit glass cleaner on white film.
- Refer to maintenance instructions.

6 Reference Materials

A. Component Functions

1. Control Box

- The control box is located under a small cover in the right rear corner of the inside of the hopper.
- There is a light located inside of the control box. The internal light will turn green when the appliance has reached a temperature of 200°F (93°C) in the fire pot and will turn red when it reaches 600°F (315°C).
- There is also an internal blue light located in the upper left corner of the control box. When you plug in the appliance the blue light will automatically start blinking 1 blink every 10 seconds for the first 60 seconds and then will stop.

NOTE: Do NOT open the control box. This will void the warranty. If you need to plug in or remove the control box you must first unplug the appliance.

2. Convection Blower

The convection blower is mounted at the bottom rear of the appliance. There are 2 impellers, one on each side of the motor. The convection blower pushes heated air through the heat exchange system into the room.

3. Combustion (Exhaust) Blower

The combustion blower is mounted on the lower left side on rear of appliance. The blower is designed to pull the exhaust from the appliance and push it out through the venting system.

4. Feed System

The feed system is located in the hopper under the feed motor cover box on the left side of the appliance and can be removed as an entire assembly. The assembly includes the feed motor, mounting bracket, bearing and feed spring (auger). The hollow feed spring (auger) pulls pellets up the feed tube from the hopper area and drops them down the feed chute into the fire pot.

5. Fire pot

The fire pot is made of high quality ductile iron and has a cleaning pull-out rod. The floor of the fire pot opens for cleaning when you pull out the rod. Be sure that the floor returns to a completely closed position or your appliance will not operate properly.

6. Fuse

The fuse is located on the front of the junction box on the right side of the appliance. The fuse will blow should a short occur and shut off power to the appliance.



When describing the location of a component, it is always AS YOU FACE THE FRONT OF THE APPLIANCE.

7. Heat Exchangers

The heat exchangers transfer hot air from the exhaust system into convection air. Lift the appliance top to access the heat exchangers. There are 2 clean out rods located under the heat exchangers.

8. Heat Output Switch

The heat output switch is located on the upper right side panel. The function of the heat output switch is to regulate the burn rates; low, medium, and high settings.

9. Hopper Switch

The hopper switch is located in the upper right hand corner of the hopper. This switch is designed to shut down the feed motor whenever the hopper lid is opened.

10. Igniter

The igniter is mounted on the base of the fire pot. Combustion air travels over the red hot igniter creating super heated air that ignites the pellets.

11. Junction Box And Wiring Harness

The junction box is located on the right side of the appliance, behind the interior shield. The junction box and wiring harness are replaced as one component.

12. Power Supply

The power outlet is located on the back of the appliance, lower right corner. Check the wall receptacle for 120 volt, 60 Hz (standard current). Make sure the outlet is grounded and has the correct polarity. A good surge protector is recommended.

13. Red Call Light

The red call light is on the front of the junction box, next to the reset button. The function of the red call light is to indicate that the thermostat is calling for heat.

14. Reset Button

The reset button is located on the right side of the appliance next to the red call light. The function of the button is to momentarily open the thermostat circuit, which restarts the system.

15. Thermocouple

The thermocouple is located on top of the fire pot inside the thermocouple cover (ceramic protection tube). The thermocouple sends a millivolt signal to the control box indicating the preset temperatures of the green and red lights have been obtained.

16. Thermostat

The appliance is designed to run on a 12 volt AC thermostat. The heat anticipator should be set on the lowest setting available.

17. Snap Disc #1 (Convection Blower) 145°F

Snap disc #1 is located on the right side of the appliance on the top of the heat exchanger box. There are 2 purple wires connected to it. This snap disc turns the convection blower on and off as needed. Power is always present at snap disc #1.

18. Snap Disc #2 (Thermostat Override) 200°F

Snap disc #2 is also located on the right side of the appliance between snap disc #1 and convection blower. There are 2 yellow wires connected to it. This snap disc will turn off the feed system, which will turn off the appliance if an over fire condition should occur or if the convection blower should fail to operate.

19. Snap Disc #3 (Back Burn Protector) 250°F

Snap disc #3 is mounted on the side of the auger tube just below the feed motor and has a red reset button. To access it remove the feed motor cover box from inside the hopper. If the fire tries to burn back into the feed system or push exhaust up the feed tube, this snap disc will shut the entire system off. This disc must be manually reset.

20. Vacuum Switch

The vacuum switch is located on the left side of the appliance behind the inner shield. This switch turns the feed system on when vacuum is present in the firebox. The vacuum switch is a safety device to shut off the feed motor if the exhaust or the heat exchanger system is dirty or plugged or if the firebox door is open.

21. Wiring Harness

See **Figure 29.1** below.

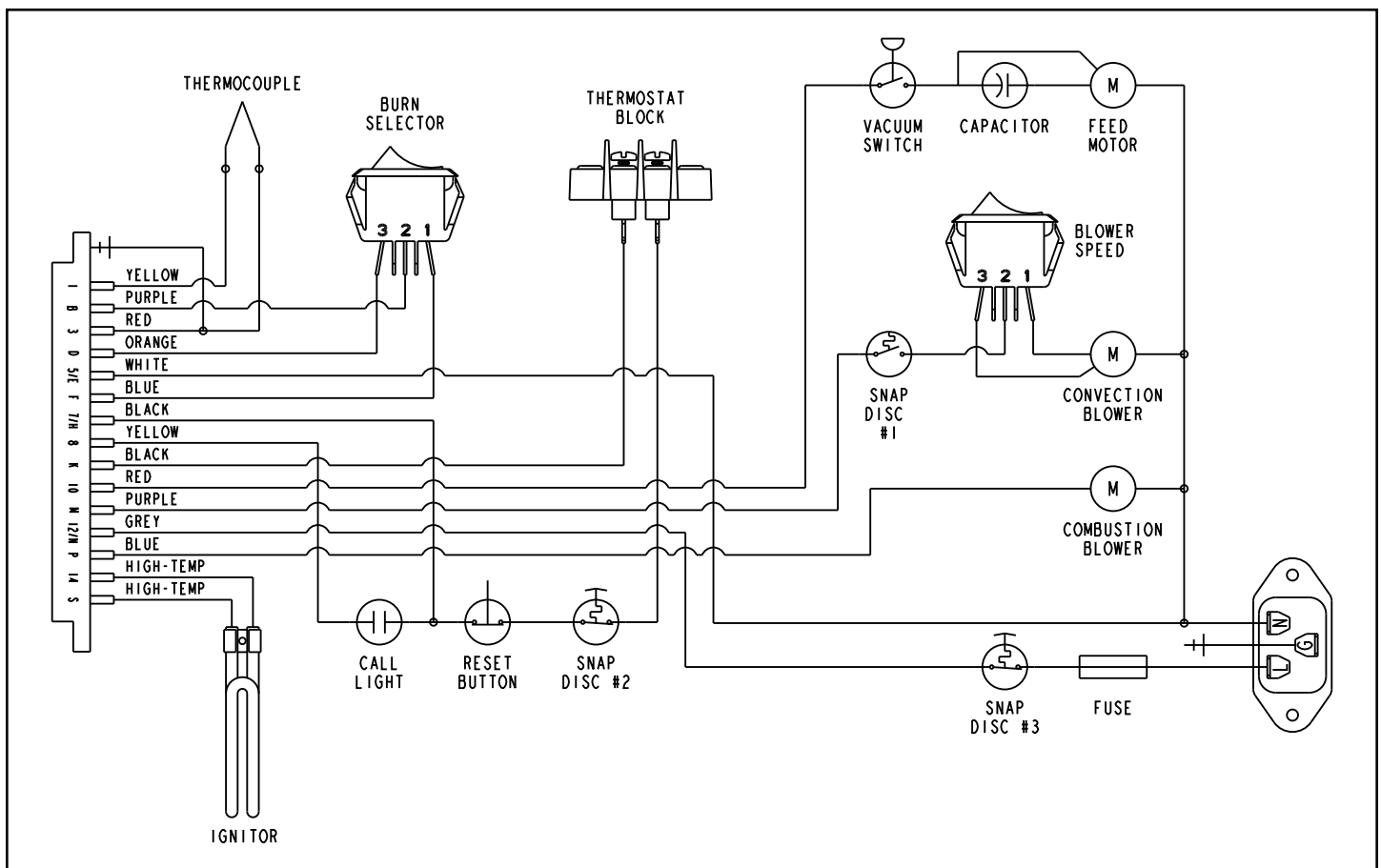

Figure 29.1

B. Component Locations

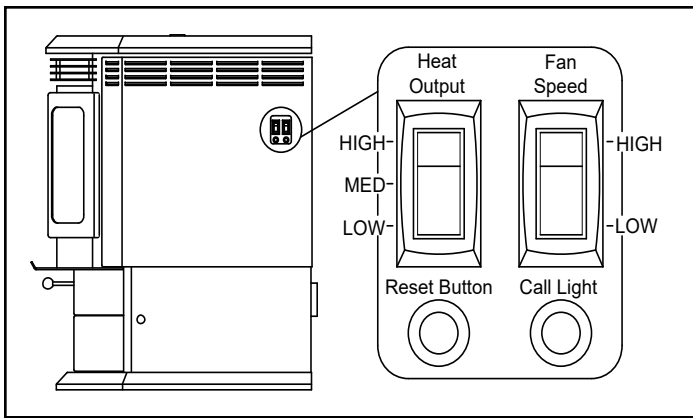

Figure 30.1

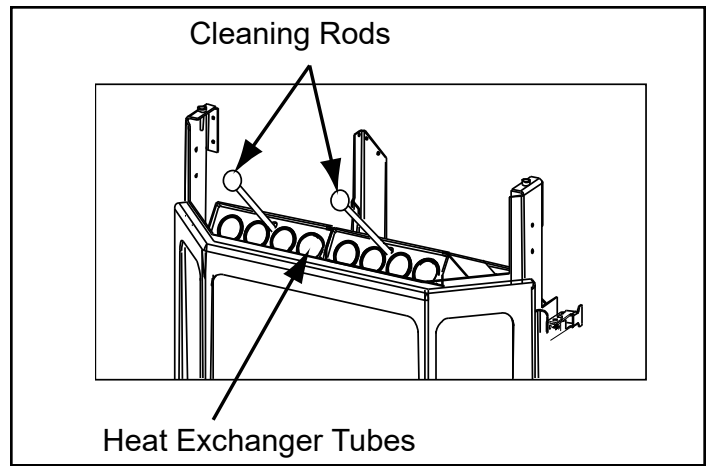

Figure 30.2

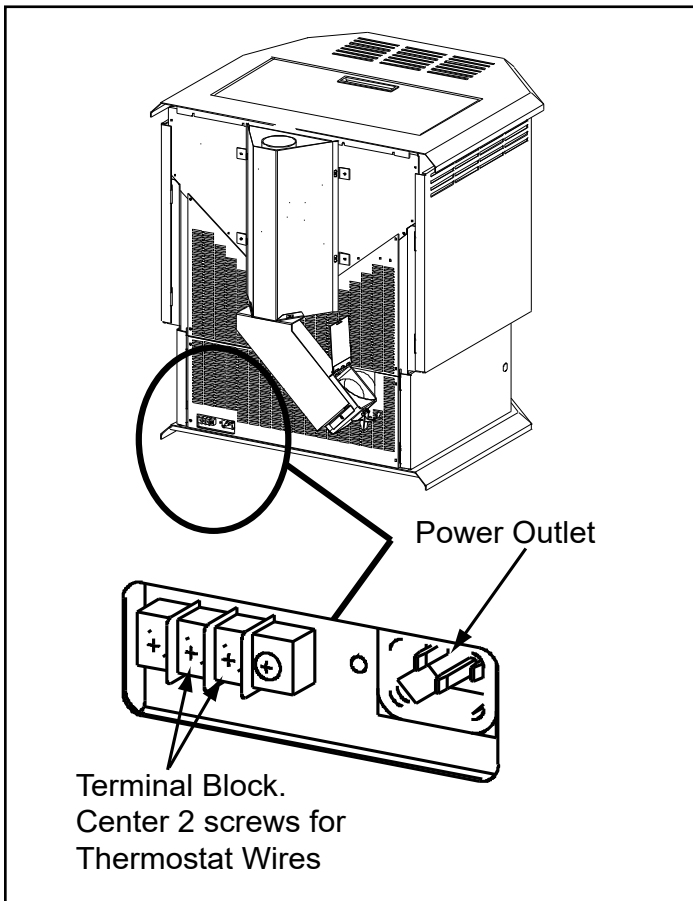

Figure 30.3

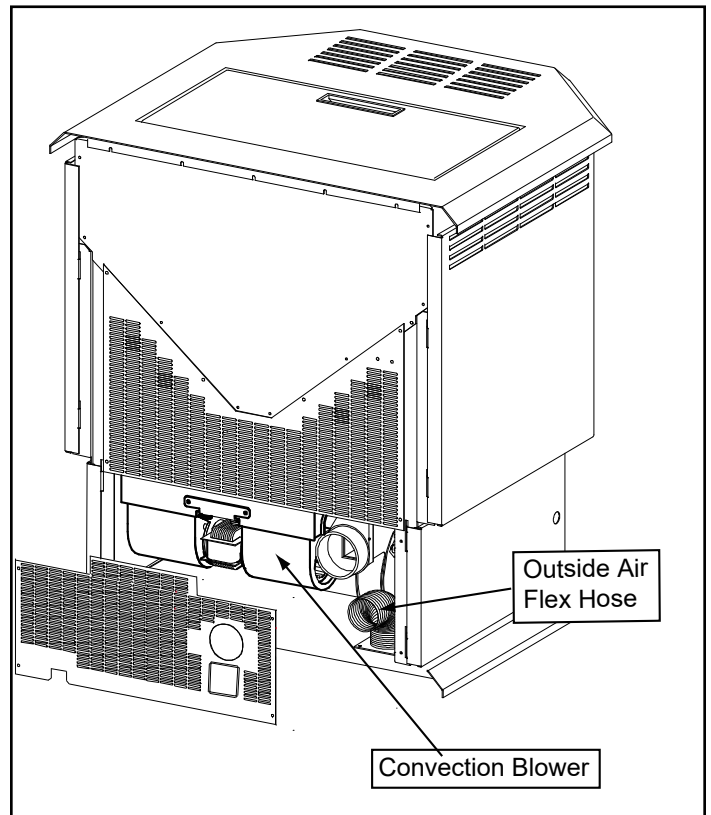
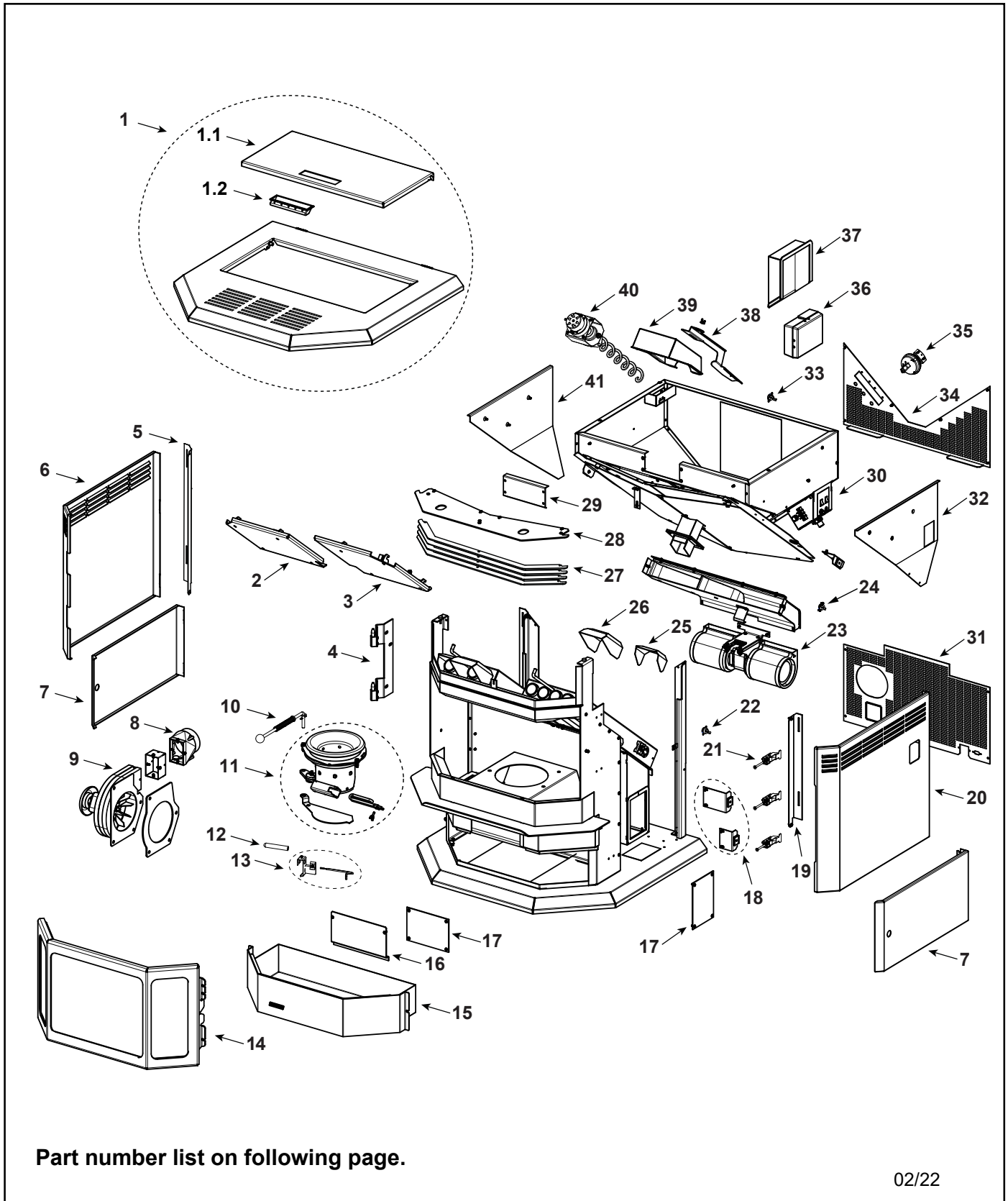

Figure 30.4



Part number list on following page.

02/22

IMPORTANT: THIS IS DATED INFORMATION. Parts must be ordered from a dealer or distributor. **Hearth and Home Technologies does not sell directly to consumers.** Provide model number and serial number when requesting service parts from your dealer or distributor.



Stocked at Depot

ITEM	DESCRIPTION	COMMENTS	PART NUMBER	
1	Top Assembly	with Hopper Lid	SRV7027-039	
1.1	Hopper Lid Assembly		SRV7027-036	
	Hopper Lid		SRV410-4901	
1.2	Handle, Hopper Lid		SRV200-0110	
	Bushing, Hopper Lid	Pkg of 2	812-1010	
	Magnet, Round		SRV7000-140	Y
	Bumper, Rubber	Pkg of 12	SRV224-0340/12	Y
	Screw, Flat Head Philips 8-32X1/2	Pkg of 12	220-0490/12	Y
	Hopper Lid Magnetic Switch		SRV7000-375	Y
2	Baffle Assembly Left		510-5350	
3	Baffle Assembly Right		510-5360	
4	Hinge Plate		812-4030	
	Hinge, Door, Male		SRV450-2810	
	Screw, Pan Head Phillips 10-32 X 3/8	Pkg of 40	21799A/40	Y
5	Curtain Mount, Side Left		410-5251	
6	Curtain, Side Left		812-3840	
7	Curtain, Pedestal Side	Right or Left	410-5391	
8	Casting, Exhaust Transition		180-0190	
9	Exhaust Combustion Blower, 80 CFM		812-3381	Y
	Gasket, Exhaust Combustion Blower, between...	...Motor & Housing	812-4710	Y
		Motor & Housing Pkg of 12	SRV240-0980M	Y
		...Housing & Stove	SRV240-0812	Y
		Motor & Housing Pkg of 12	SRV240-0812M	Y
	Silicone, Hi-Temp, 11 oz.		812-2020	Y
<p>#10 Rod/Linkage</p>				
10	Rod/Linkage, Ez Clean		812-3850	
10.1	Knob, Ash Dump Control Rod		832-3020	
10.2	Spring, Firepot		200-2050	
10.3	Washer, 5/16	Pkg of 10	7000-579/10	Y
		Pkg of 50	3-30-0205-50	Y

Additional service part numbers appear on following page.

IMPORTANT: THIS IS DATED INFORMATION. Parts must be ordered from a dealer or distributor. **Hearth and Home Technologies does not sell directly to consumers.** Provide model number and serial number when requesting service parts from your dealer or distributor.



**Stocked
at Depot**

ITEM	DESCRIPTION	COMMENTS	PART NUMBER	
#11 Firepot Assembly				
11	Firepot Assembly		812-3351	Y
	Nut, Lock 1/4-20	Pkg of 25	226-0090/25	Y
		Pkg of 50	3-30-8021-50	Y
	Bushing, Firepot		410-8320	Y
	Floor, Firepot		414-0290	Y
	Gasket, Firepot		SRV510-0530	Y
11.1	Heating Element Assembly 18" (Loop Igniter)	Pkg of 1	SRV7000-462	Y
		Pkg of 10	SRV7000-462/10	Y
	Wing Thumb Screw 8-32 X 1/2	Pkg of 24	7000-223/24	Y
11.2	Combustion Plenum Trap Door		812-4100	
12	Thermocouple Cover	Qty: 1	812-1322	Y
		Pkg of 10	812-4920	Y
13	Thermocouple		812-0210	Y
13.1	Thermocouple Bracket W/Set Screw		812-3171	Y
#14 Door Assembly				
14	Door Assembly	Black	DR-CB12-MBK-B	
14.1	Hinge, Female		SRV450-2910	
14.2	Glass Assembly, Center - 13-7/8" W x 11" H		SRV510-5400	Y
14.3	Glass Assembly, Side, 1 Pc - 5-1/8" W x 11" H	Interchangeable	SRV510-5410	Y
14.4	Glass Retainer Assembly		SRV510-5460	
	Nut, Keps Lock, 8-32	Pkg of 40	226-0060/40	Y
14.5	Bracket, Door Latch		SRV410-4912	
	Door Rope, 7/8", Field Cut to Size	8 Ft.	842-2350	Y
	Gasket, Glass, Field Cut to Size	10 Ft.	833-0660	

Additional service part numbers appear on following page.

IMPORTANT: THIS IS DATED INFORMATION. Parts must be ordered from a dealer or distributor. **Hearth and Home Technologies does not sell directly to consumers.** Provide model number and serial number when requesting service parts from your dealer or distributor.



Stocked at Depot

ITEM	DESCRIPTION	COMMENTS	PART NUMBER	
15	Ashpan		812-4050	
	Gasket, 7/16"	10 Ft	844-6730	Y
	Logo, Quadra-Fire		7000-649/10	
	Silicone, Hi Temp, 11oz		812-2020	
16	Panel, Front Access		410-5161	
17	Door Exhaust Plenum Cleanout Plate	Qty 2 req	410-4871	
18	Latch, Magnetic (Small & Large)		812-3821	
	Latch, Magnet		SRV229-0631	Y
	Screw, 8-32 x 1/4	Pkg of 40	225-0240/40	Y
19	Mount, Side Curtain, Right		410-5261	
20	Curtain, Side Right		812-3800	
21	Latch, Draw	Qty 6 req	229-0640	Y
22	Snap Disc, Convection Blower (#1)		SRV230-0060	Y
23	Convection Blower, 130/60 CFM		812-3370	Y
	Nut, Keps Lock, 8-32	Pkg of 40	226-0060/40	Y
	Screw, Pan Head Phillips 8-32 X 3/4	Pkg of 24	229-1100/24	Y
24	Snap Disc, 200 Open/40 D (#2)		SRV230-0900	Y
	Bracket, Snap Disc		SRV7005-253	
25	Director, Air, Large		410-8250	
26	Director, Air, Small		410-8260	
27	Grille, Louver	Black	LVGRL-CB12-BK-B	
	Grille, Bar, Bottom		410-8330	
	Screw, Pan Head Phillips 10-32 X 3/8	Pkg of 40	225-0500/40	Y
28	Extension, Heat Shield Top		410-5322	
	Screw, Pan Head Phillips 10-32 X 3/8	Pkg of 40	225-0500/40	Y
29	Panel, Feed Motor Access		410-6220	
30	Wire Harness, Junction box		SRV7000-154	Y
	Block, Thermostat Term Dv		SRV230-0690	
	Igniter Extension		7000-218	
	Call Light, Fluorescent - New Style Junction Box		SRV7000-122	
	Fuse, Amp 7, Junction Box	Pkg of 10	812-0380/10	Y
	Fuse Holder		812-0401	Y
	Reset Button Assembly		SRV7000-040	
	Rocker Switch, 3-Position	Heat Output	812-3500	Y
	Switch, Rocker (Fan Speed)		812-3910	
31	Panel, Rear Access, Bottom		410-5413	

Additional service part numbers appear on following page.

IMPORTANT: THIS IS DATED INFORMATION. Parts must be ordered from a dealer or distributor. **Hearth and Home Technologies does not sell directly to consumers.** Provide model number and serial number when requesting service parts from your dealer or distributor.



Stocked at Depot

ITEM	DESCRIPTION	COMMENTS	PART NUMBER	
32	Deflector, Air, Right Curtain		410-5105	
33	Snap Disc, Manual Reset (#3)		SRV230-1290	Y
34	Panel, Rear Access, Top		410-4352	
35	Vacuum Switch		SRV7000-531	Y
	Hose, Vacuum, 5/32	Qty 3 ft req	SRV240-0450	Y
	Hose, Barb Assembly		SRV229-0920	
36	Control Board 3 Speed		SRV7000-704	Y
	Fuse, 8 Amp, Control Box	Pkg of 10	812-3780/10	Y
37	Cover, Control Box		410-6321	
38	Feed Adjustment Plate		812-4170	
39	Cover, Feed Motor		SRV7027-071	

#40 Feed Motor Assembly

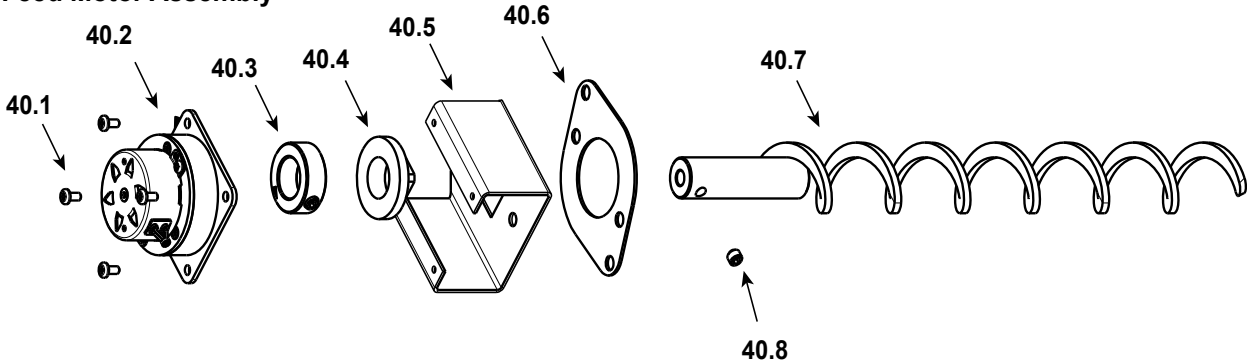

40	Feed Motor Assembly		812-3690	Y
40.1	Screw, 8-32 X 3/8 PH	Pkg of 40	225-0500/40	Y
40.2	Feed Motor		812-4421	Y
40.3	Collar, Set, 7/8		229-0520	
40.4	Feed Bearing		SRV7000-598	Y
40.5	Mount, Feed Motor		410-7172	
40.6	Gasket, Feed Motor		SRV240-0731	Y
40.7	Feed Spring Assembly		SRV7027-024	Y
40.8	Screw, 5/16-18 X 1/4	Pkg of 25	225-0550/25	Y
41	Deflector, Air, Left Curtain		410-4992	
	Component Pack		SRV7127-017	
	Cleanout Tool		SRV414-1140	Y
	Harness, Thermostat Wire		230-0810	
	Paint Touch-Up, 4 oz		812-0910	
	Power Cord		812-1180	Y
	Thermostat, Programmable		PROG-STAT	

Additional service part numbers appear on following page.

QUADRA-FIRE®

NOTHING BURNS LIKE A QUAD

CONTACT INFORMATION

Hearth & Home Technologies
352 Mountain House Road
Halifax, PA 17032
Division of HNI INDUSTRIES

Please contact your Quadra-Fire dealer with any questions or concerns.
For the number of your nearest Quadra-Fire dealer
log onto www.quadrafire.com



CAUTION



DO NOT DISCARD THIS MANUAL

- Important operating and maintenance instructions included.
- Read, understand and follow these instructions for safe installation and operation.
- Leave this manual with party responsible for use and operation of this appliance.



We recommend that you record the following pertinent information for your heating appliance.

Date purchased/installed: _____

Serial Number: _____

Location on appliance: _____

Dealership purchased from: _____



Dealer Phone: 1() - _____

Notes: _____

This product may be covered by one or more of the following patents: (United States) 5341794, 5263471, 6688302, 7216645, 7047962 or other U.S. and foreign patents pending.

HEARTH & HOME
technologies™

Appendix B – Dilution Tunnel Used & Schematic

Information	Tunnel 1	Tunnel 2	Tunnel 3
Name of Tunnel	6" Dilution Tunnel	6" Dilution Tunnel	12" Dilution Tunnel
Location of Tunnel	OMNI Test Lab, Emissions Booth 1	OMNI Test Lab, Emissions Booth 2	OMNI Test Lab, Emissions Booth 3
Presence of Mixing Baffles (EPA 5G)	Two steel semicircles on opposite sides of the duct midway between the T connector and elbow upstream of sampling section (available but not used)	Two steel semicircles on opposite sides of the duct midway between the T connector and elbow upstream of sampling section (available but not used)	There are no mixing baffles
Presence of mixing section (ASTM E2515)	5' mixing section of dilution tunnel	5' mixing section of dilution tunnel	5' mixing section of dilution tunnel
Description of Tunnel Turns	Steel T connector and 90° elbow are used for connecting mixing section, the sampling section. The elbow before the sampling section begins is of the same 6" diameter as the sampling section straight ducting	Steel T connector and 90° elbow are used for connecting mixing section, the sampling section. The elbow before the sampling section begins is of the same 6" diameter as the sampling section straight ducting	Steel T connector and 90° elbow are used for connecting mixing section, the sampling section. The elbow before the sampling section begins is of the same 12" diameter as the sampling section straight ducting
Diameter of Horizontal Flue Section	6"	6"	12"
Diameter of Sampling Section	6"	6"	12"
Photograph of Tunnel Apparatus			

Example of ASTM E2515-11 Dilution Tunnel

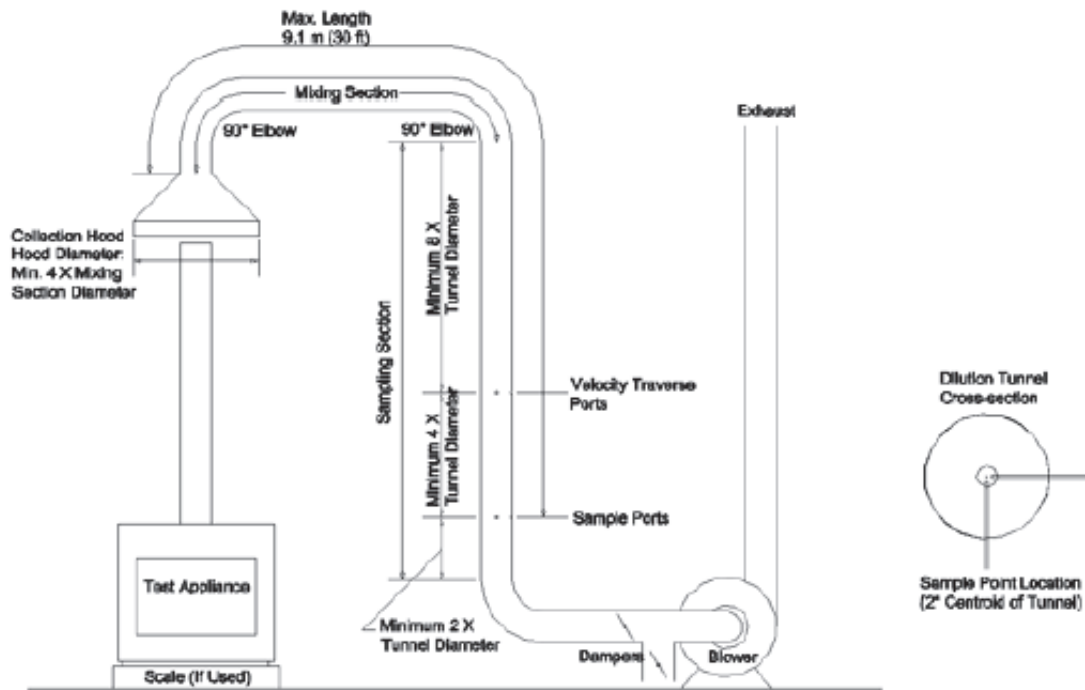

Prior to testing, sample point and travers point locations are verified to ensure placement is within specifications. Collection hood, tunnel diameter, and mixing section length are also verified to be within specifications.

Appendix C – Revision History

Date	Project No.	Tech. & Evaluator	Report Sect.	Summary of Changes
02/01/2019	0061PN013E (Edition 000)	Bruce Davis Alex Tiegs	ALL	First Issue of Report
08/08/2023	0061PN013E (Edition 001)	Riley Tiegs Ken Morgan	Preface	Updated report edition, signatories, and table of contents for report renewal
			Section 1	Uncorrected emission values & explanation added to Table 1
				Added table 5 to report to show train precision (pg6)
				Results Summary now addresses run appropriateness. Added statement that the operation of the appliance was gathered from the Owner’s Manual. (pg7).
			Appendix B	This appendix was created to include the dilution tunnel schematic to report and lab tunnel specs
			Appendix C	Revision History appendix added to report
			Appendix A	New manual added to report
			Section 2	Uncorrected Emission Values added (pg14)
08/14/2023	0061PN013E (Edition 002)	Riley Tiegs Ken Morgan	Section 1	Train Precision Table 5 added. This was mistakenly omitted in Edition 001
02/07/2024	0061PN013E (Edition 003)	Riley Tiegs Ken Morgan	Appendix A	New Labels added
2/19/24	0061PN013E (Edition 004)	Ken Morgan	Section 2, Page X	Added manufacturer’s written instructions.